

Industrial

# Digital Cameras for Microscopy

Camera Overview For Materials Science Microscopes

More Detail, Faster Inspections



**EVIDENT**

# Passionate about Imaging

Versatility, performance, and precise color reproduction are characteristics all our microscope cameras share. We're committed to providing innovative cameras that capture the clear, reliable images critical to every microscopist. Our comprehensive range of digital cameras for materials science are optimized for various applications, so you can choose the one that works best for you.

## Advanced Digital Camera for Challenging Applications: DP75 Digital Microscope Camera

Make your microscope inspections more efficient with the powerful DP75 digital microscope camera. This high-performance tool is tailored for a range of applications and enables you capture high-resolution brightfield, darkfield, MIX (brightfield+ darkfield), polarization, DIC, fluorescence, and near-infrared (NIR) observation images.\*

### Exceptional Imaging for Challenging Inspection Applications

#### Better Clarity and Precision

Experience sharp, low-noise inspection images. The camera's leading-edge TruAI denoise algorithm enhances the image quality while our improved multiple-axis color correction technology delivers outstanding color fidelity for vivid reproductions and the RGB color reproducibility needed for printed materials and LCD color filters.



An image of printed paper

#### Fast Frame Rate at High Resolution

With a fast frame rate of 22 fps at over 4k resolution and 60 fps at full HD resolution, you can check live images while moving at a fast pace, speeding up your inspection and analysis workflow.

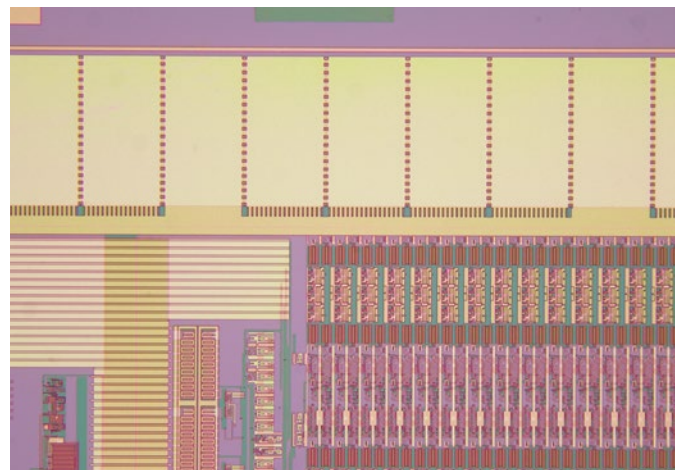

An image of a wafer

#### High-Resolution Images at Low Magnification

The camera's pixel shifting makes it possible to capture high-resolution images even at low magnification with a maximum resolution of 8192 × 6000.

#### Flexible Upgrades

Since the DP75 camera uses USB 3.1 Gen2, it is compatible with most PCs and can easily be bought as an upgrade for your current system.

\*A microscope system for NIR observation is required.

## Find Flaws Fast

A sample's appearance can vary depending on the quality of the material, surface conditions, or illumination methods. To show samples accurately, the camera's live high dynamic range (HDR) combines several images taken at different exposures to correct for brightness differences on the sample's surface. Live HDR provides high-fidelity images that show not only textures but also flaws and defects that were previously undetectable. Glare is also reduced for more comfortable observation.

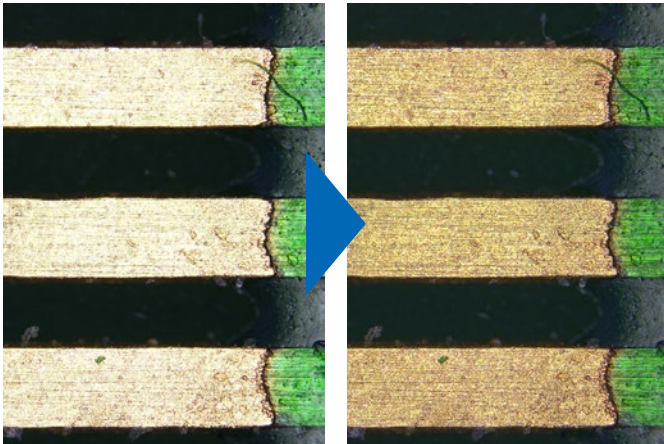

Halation removal via HDR (Sample: a printed circuit board (PCB))

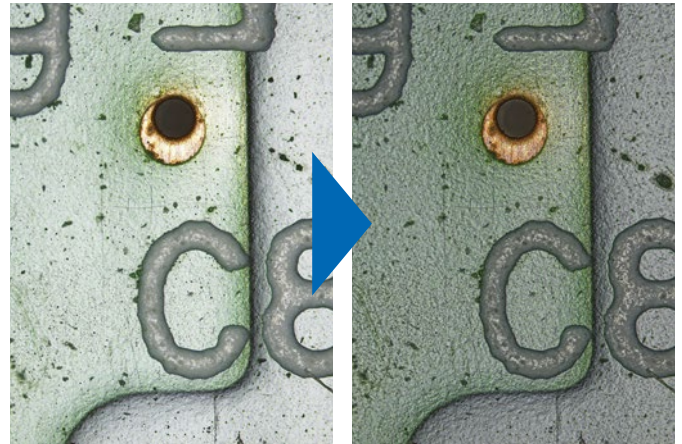

Texture enhancement via HDR (Sample: a printed circuit board (PCB))

## See More in One Image

The camera's wide field of view (FN 26.5) enables you to quickly observe a large area, making your inspections faster and more efficient.



The DP75 camera's field of view when used with the 0.63× camera adapter (red frame) compared to the DP74 (predecessor) camera's field of view when used with the 0.63× camera adapter (blue frame)

## Easy Fluorescence to Infrared Imaging using the Same Microscope Camera

Engineered to excel in various applications, the DP75 camera integrates numerous benefits with a high-sensitivity cooled CMOS sensor and a switchable infrared (IR) cut filter. Benefits include:

- › Covers a wide range of wavelengths: the DP75 supports wavelengths from the visible light up to 1000 nm, enabling you to capture exceptional quality brightfield, darkfield, MIX (brightfield+darkfield), polarization, DIC, fluorescence, and NIR\* observation images.
- › Clear fluorescence images with minimal noise: capture high-quality images even if the fluorescence is weak, which is helpful in applications such as examining resist residues.

\*A microscope system for NIR observation is required

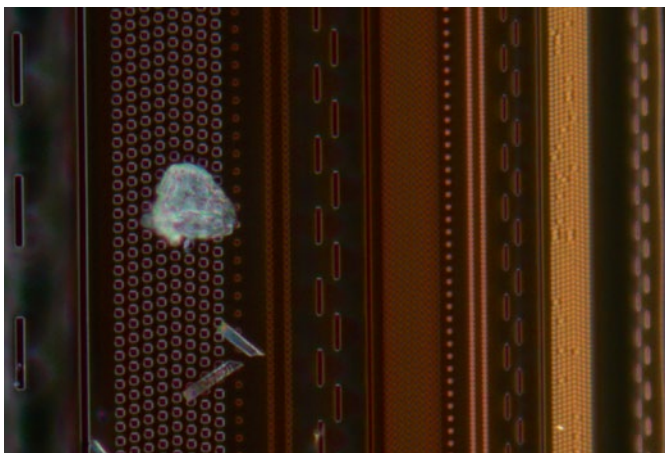

A MIX (fluorescence+darkfield) observation image of a photoresist residue on a semiconductor wafer

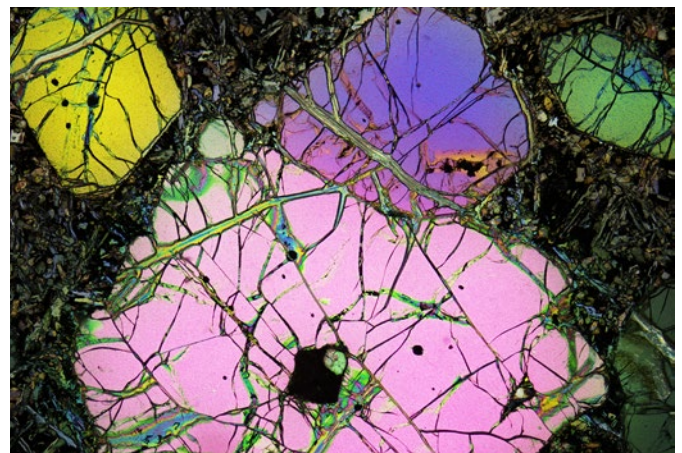

A polarized observation image of a part of mineral



A brightfield observation image of a flexible board.

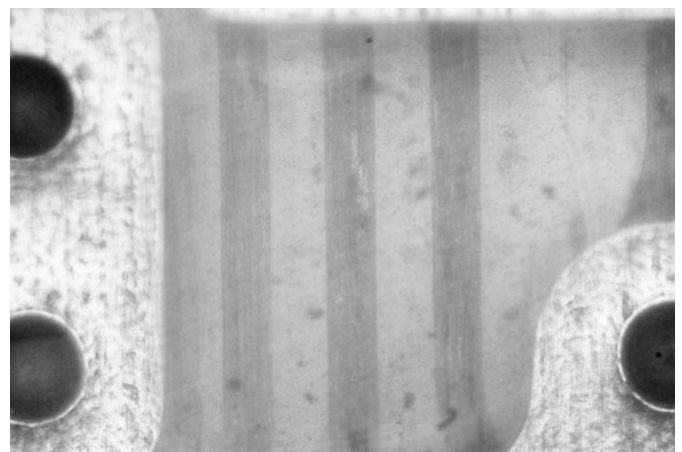

A NIR observation image of a flexible board.

# Powerful Cameras for Everyday Microscopy Applications

## DP28 and DP23 Digital Microscope Cameras

### Reliable Data from Images You Can Trust

The DP28 and DP23 cameras share a suite of smart features and precise color accuracy that make your microscopy imaging easier. The DP28 camera offers up to 4K resolution across a wide field of view to provide high-resolution images of your inspection samples that are free from artifacts. If resolution isn't your focus, the DP23 camera balances advanced functions to perform almost any imaging application.

## Efficient Inspections with Clear, Distortion-Free Images DP28

### High-Quality and High-Resolution 4K Images

View your samples in stunning 4K resolution to see even the finest details under low magnification.

### Comfortably View Images on Screen DP28

Whether you're showing your samples on a monitor or a projector, the images on the screen look exactly as they appear through the microscope's eyepieces, so you know you're not missing details or data. The DP28 camera's 8.9-megapixel CMOS sensor and global shutter capture full-HD-quality images at 60 fps, so your samples render clearly. If you move your sample or the microscope stage, the image is displayed with no wobbling or tearing artifacts, so you can scan samples even faster.

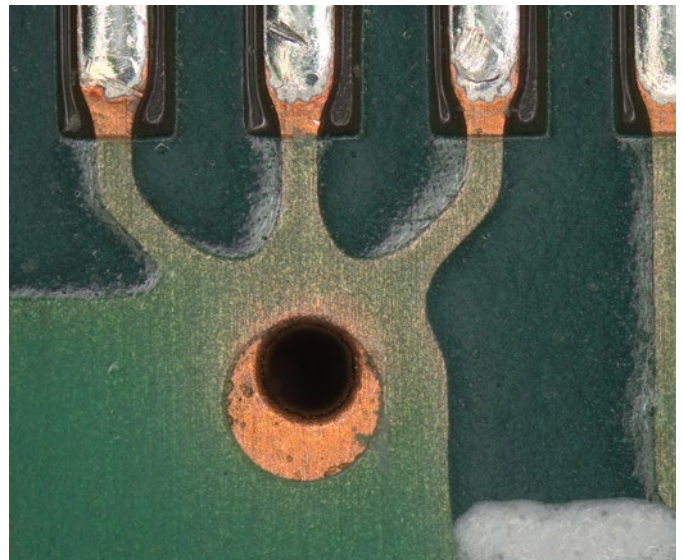

## The Right Balance of Resolution and Speed DP23

The 6.4-megapixel DP23 camera can capture full-HD-quality images at up to 60 frames per second (fps), so you can obtain images with the level of detail you need quickly and efficiently.

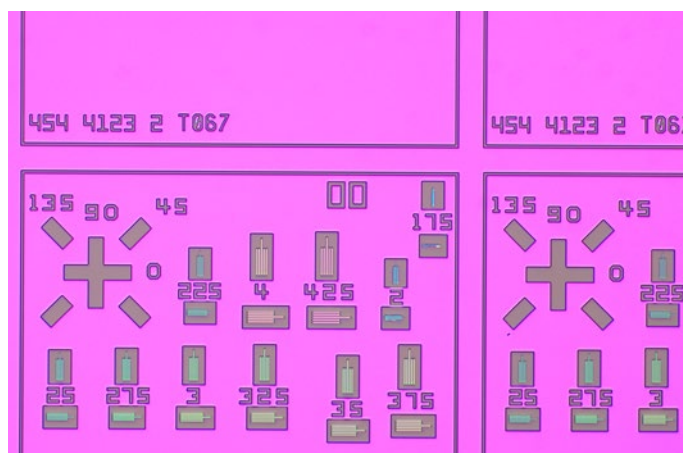

## Accurate Color Reproduction Improves Inspection Quality

### DP23 DP28

The DP28 and DP23 cameras provide reliable color accuracy. Dedicated ICC profiles show your samples in their natural colors to more easily spot defects.

# Easy to Use with Minimal Training

## High Frame Rate for Smooth Navigation in Low Light

DP23

DP28

The Fast Live function provides a consistently high frame rate during long-exposure imaging, so your image remains smooth when scanning samples, even under low light conditions.

## Confirm that Your Measurement Area Is in Focus

DP23

DP28

Make sure that your measurement area is properly focused using the Focus Peaking function.\* The software shows a map of the sample with the in-focus areas in color and the out-of-focus areas in grayscale.

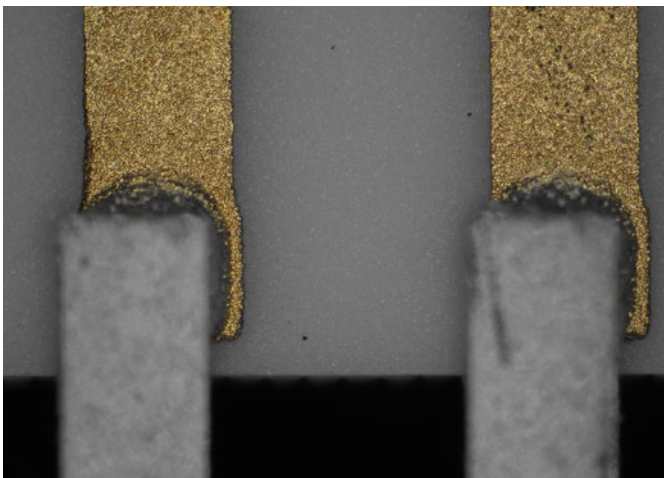

Focused on the lower layer

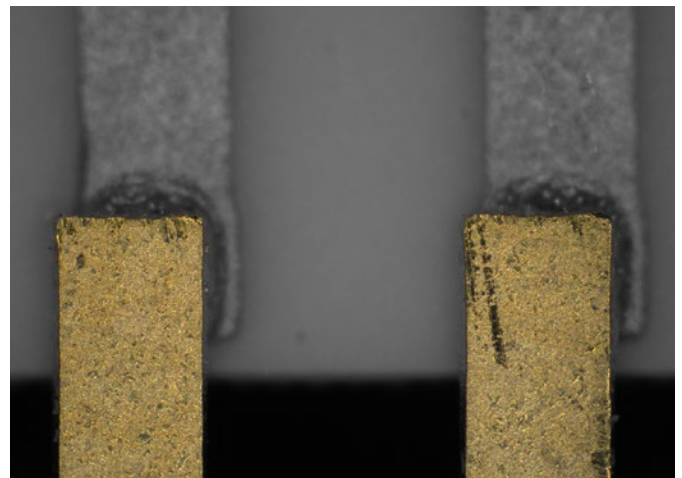

Focused on the upper layer

## Find Defects Fast

DP23

With a field of view up to FN25, you can spot defects faster since you can see more of your sample at a glance. This means you spend less time scanning around the sample during the inspection and more time evaluating what you're seeing on the screen. Avoid the time-consuming process of stitching multiple smaller images together, so you can be more productive and efficient.

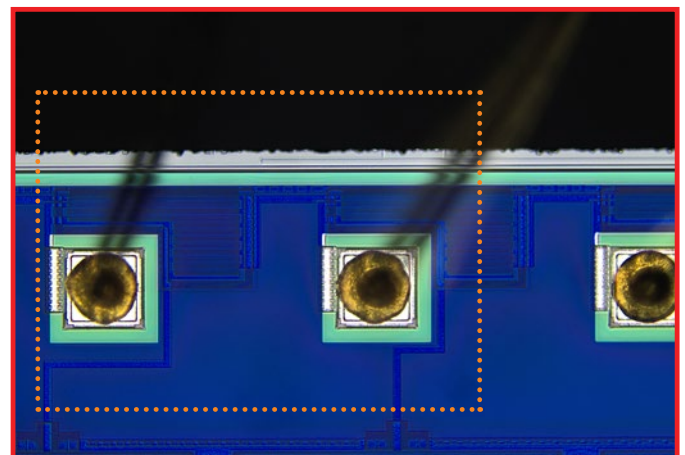

The DP23 camera's field of view when used with the 0.35× camera adapter (red frame) compared to the conventional camera's field of view when used with the 0.35× camera adapter (dotted frame)

\*Available in PRECIV software.

# Efficient Workflow

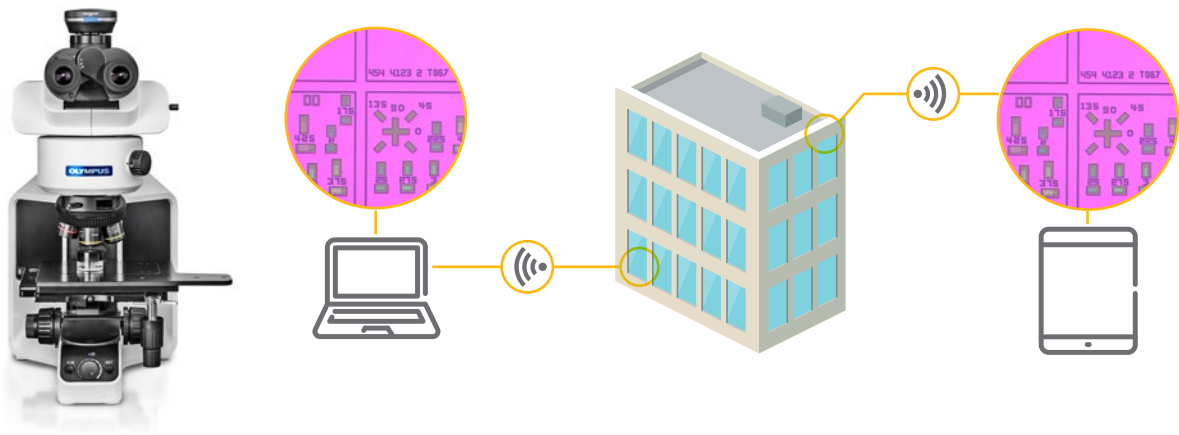

## Easily Share Images Outside Restricted/High-Security Areas

DP23

DP28

All your critical data—images, annotations, and analytics—can be displayed and shared together locally or remotely using the camera's AOU software with network controller. This provides a much simpler solution than relying on email attachments to discuss images and results with colleagues. And thanks to support for network security protocols such as NIST and GDPR along with antivirus support, you can share your data safely.\*

For complex or advanced image analysis, both cameras are compatible with OLYMPUS Stream software to further streamline your workflow.

## Capture Clear Images from Dim Samples

DP23

DP28

When making observations using polarization, the High Contrast mode enables easier image acquisition with a high signal-to-noise ratio so that you can capture high-quality images from dim samples.

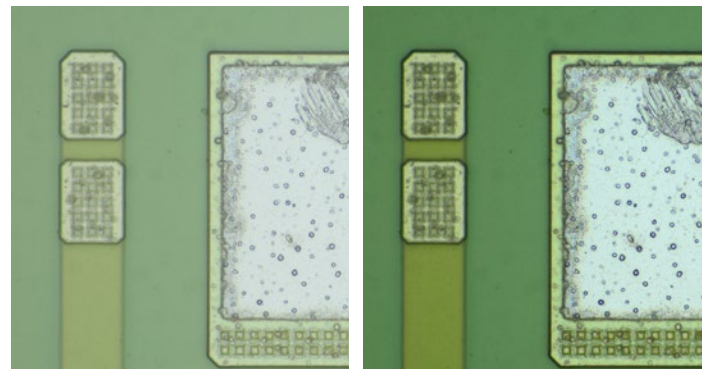

Without contrast mode vs with contrast mode

## Save Valuable Work Space

DP23

DP28

You can attach the camera's stand-alone module to the back of a monitor using a VESA adaptor to keep it off the desk and out of the way.



\*Antivirus software is optional.

# See Fine Details Under Low Magnification

## SC180 Digital Microscope Camera

### Capture More Detail

If you prefer a camera with high resolution and 4K capabilities but don't need the highest levels of field of view, frame rate, and signal-to-noise ratio, consider the SC180 digital camera.

With almost four times more pixels than a standard microscope camera, the 18-megapixel SC180 camera's high resolution enables you to capture images with a high level of detail, so you can zoom in to view fine structures using low-power objectives.

### Advanced Image Tools

The camera supports the advanced imaging tools found in DP series cameras, including:

- › Olympus Smart Image Averaging
- › Automatic white balance
- › Focus peaking
- › Fast Live

### Good Color Reproduction

Integrated shading correction and a sharpness filter help you view color details and subtle variations in your samples.

### Affordable 4K Live Images

4K live images enable you to engage colleagues by showing detailed images on a screen or monitor. When showing a live image, you can pan across the sample and zoom in to view fine details.

## Microscope Digital Camera Line up

	DP75	DP28	DP23
Resolution (megapixels)	49.2	8.9	6.4
Imaging sensor size	1.1 in. Color CMOS	1 in. Color CMOS	1/1.8 in. Color CMOS
Pixel size (µm)	3.45 × 3.45	3.45 × 3.45	2.4 × 2.4
Exposure times	28µs – 120s	27 µs – 15 s	29 µs – 15 s
Dynamic range* <sup>1</sup>	12-bit	10-bit	10-bit
Live frame rates* <sup>2</sup>	60 to 22	64 to 30	60 to 30
IR cut filter	Switchable In: 400 nm ~ up to 650 nm Out: 400 nm ~ up to 1000 nm	—	—
Dimensions (Ø × H)	116 mm × 92.3 mm (4.6 in. × 3.6 in.)	76.7 mm × 37.3 mm (3 in. × 1.5 in.)	76.7 mm × 37.3 mm (3 in. × 1.5 in.)
Weight (approx)	1400 g (49.4 oz)	380 g (13.4 oz)	380 g (13.4 oz)
3CMOS mode	Available	—	—
LiveHDR	Available	—	—
Camera mount	C-mount	C-mount	C-mount
Stand-alone	—	DP2-AOU	DP2-AOU
PC I/F	USB3.1 Gen2	USB 3.1	USB 3.1

\*<sup>1</sup> Analog-to-digital converter. The camera's actual bit depth depends on the software used.

\*<sup>2</sup> Frame rate depends on the condition of your PC and/or software.



# Microscope Digital Camera Line up

	DP23M <sup>*3</sup>	SC180	LC35 <sup>*4</sup>
Resolution (megapixels)	6.4	18.0	3.5
Sensor size and type	1/1.8 in. Backside illuminated monochrome CMOS	1/2.3 in. Color CMOS	1/1.2 in. Color CMOS
Pixel size (µm)	2.4 x 2.4	1.25 x 1.25	2.64 x 2.64
Exposure times	0.013 ms – 25 s	22 µs – 1 s	25 µs - 1.5 s
Dynamic range <sup>*1</sup>	10-bit	12-bit	10-bit
Live frame rates <sup>*2</sup>	60 to 45	59 to 10.5	49 to 10
IR cut filter	—	—	—
Dimensions (Ø × H)	—	58 mm × 32 mm (2.3 in. × 1.3 in.)	— <sup>*5</sup>
Weight (approx)	380 g (13.4 oz)	188 g (6.6 oz)	33 g (1.16 oz)
3CMOS mode	—	—	—
LiveHDR	—	—	—
Camera adaptor	C-mount	C-mount	C-mount
Stand-alone	—	—	—
Camera I/F	USB 3.1	USB 3.0	USB 3.1

<sup>\*1</sup> Analog-to-digital converter. The camera's actual bit depth depends on the software used.

<sup>\*2</sup> Frame rate depends on the condition of your PC and/or software.

<sup>\*3</sup> PRECIV v1.1 or higher required.

<sup>\*4</sup> PRECIV v1.1: service update required.

<sup>\*5</sup> Unlike other cameras, the LC35 is not cylindrical. Dimensions (H × W × H): 47 mm x 46 mm x 24 mm (1.9 in x 1.7 in x 1.2 in).

## PC Requirements

	DP75	DP23/DP28
CPU	Intel Core i5, i7, Intel Xeon, or equivalent	Intel Core i5, i7, i9, Intel Xeon, or equivalent
RAM	16 GB (2x8 GB)	8 GB or more (dual channel) Recommended: 16GB (8GBx2: dual channel)
HDD	50 GB or more <sup>*1</sup>	30 GB or more <sup>*1</sup>
Graphic	According to PRECIV restrictions <sup>*2*3</sup>	No requirements <sup>*5</sup>
PC I/F	USB 3.1 Gen2 (TypeA) <sup>*2</sup>	USB 3.1
OS	Windows10 Pro (64-bit) Windows11 Pro (64-bit)	Microsoft Windows 10 Pro (64-bit), Microsoft Windows 10 Enterprise (64-bit) Windows11 Pro (64-bit)
DVD drive	No requirements <sup>*5</sup>	No requirements <sup>*5</sup>
Web browser	No requirements <sup>*5</sup>	No requirements <sup>*5</sup>
Others	No requirements <sup>*5</sup>	No requirements <sup>*5</sup>

<sup>\*1</sup> SSD recommended for high-speed image import

<sup>\*2</sup> Even if the PC operating environment is satisfied, it may not work properly.

<sup>\*3</sup> When using Live HDR, the NVIDIA CUDA compatible graphics board (compute capability 3.5 or higher) and Graphic board driver compatible with CUDA 11.8 or higher should be met.

<sup>\*4</sup> Operatable with USB3.1 Gen1 (5Gbps), but framerate is decreased.

<sup>\*5</sup> Please refer to the PRECIV brochure for PRECIV restrictions.

## DP23/28 Remote function (Stand-alone)

Optional license	Network solution (Remote function)*
	Anti virus software (White list type)
Web browser (Client Computer)	Microsoft Edge(chromium), Google Chrome, Safari
OS	Windows 10 Pro 64-bit, Android 9.0 or later, iOS 12.0 or later

\* Network must be within internal LAN environment. In case of wireless connection, USB WiFi adapter is required additionally.

# System Diagram

## DP23/DP28 Stand-alone Configuration

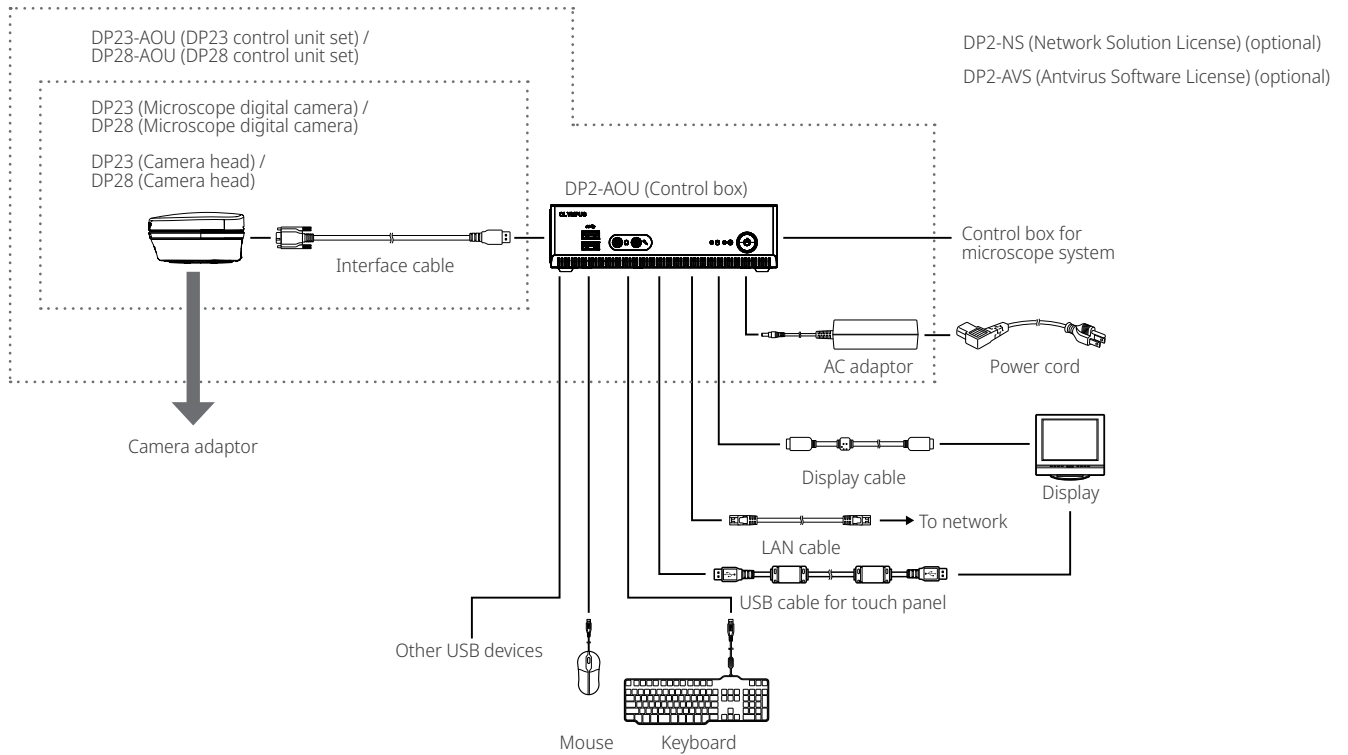

## DP23/DP28 PC Configuration

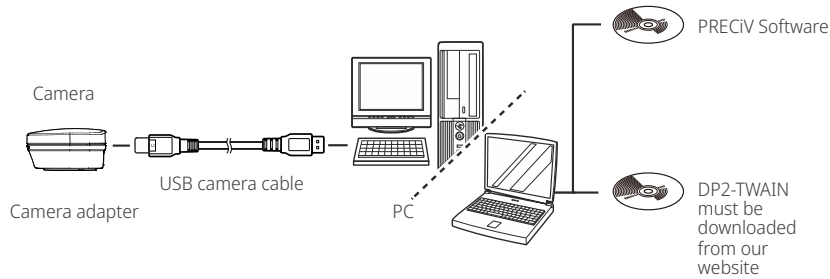

## DP23/DP28 Dimensions

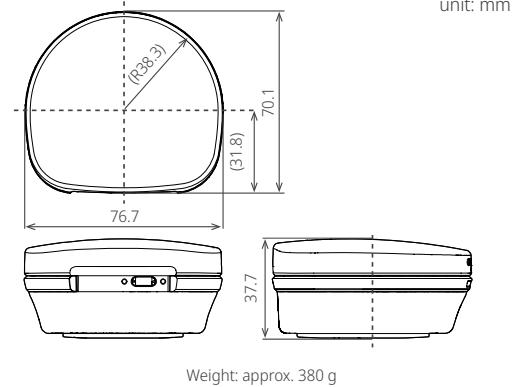

## DP75 Configuration

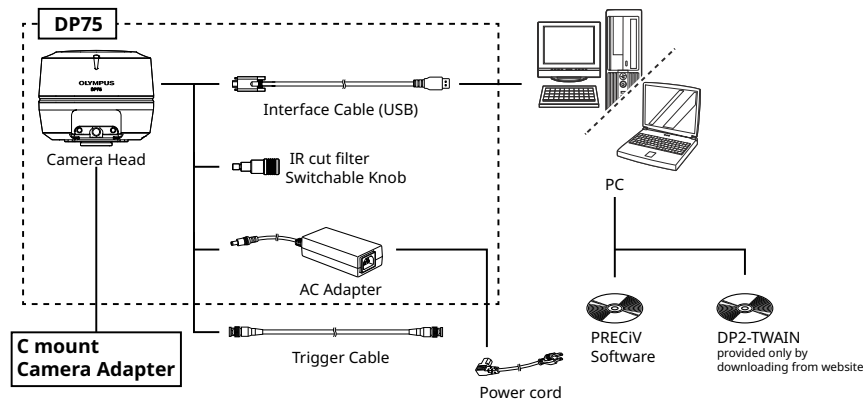

## DP75 Dimensions

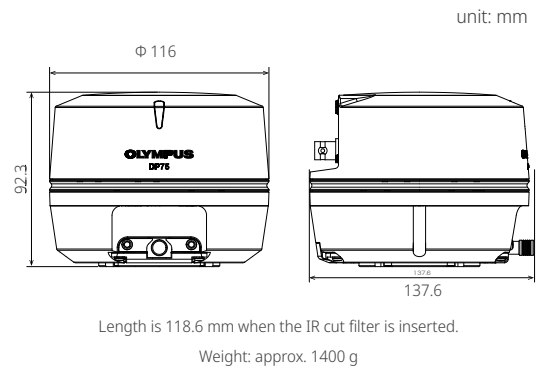

# Specifications

DP28 Specifications	PC connection* <sup>2</sup>	Stand-alone* <sup>3</sup>
Maximum Recording Pixel	4104 x 2174	
Live image display (frame rate) * <sup>1</sup>	32 fps (4104 × 2174 )	30 fps (4104 × 2174 )
	33 fps (3840 × 2160 (4K))	30 fps (3840 × 2160 (4K))
	33 fps (2168 × 2168 )	30 fps (2168 × 2168)
	64 fps (2052 × 1086 (sub-sampling 2 × 2—high speed ))	60 fps (2052 × 1086 (sub-sampling 2 × 2—high speed))
	32 fps (2052 × 1086 (binning 2 × 2—high sensitivity))	30 fps (2052 × 1086 (binning 2 × 2—high sensitivity))
	64 fps (1920 × 1080 (full HD))	60 fps (1920 × 1080 (full HD))
Compatible image display	Depends on the PC's specifications	3840 × 2160 4K UHD TV, 2560 × 1440 WQHD, 1920 × 1200 WUXGA, 1920 × 1080 FHD, 1680 × 1050 WSXGA+, 1440 × 900 WXGA+, 1366 × 768 FWXGA, 1280 × 854 HDTV (720p), 1600 × 1200 UXGA, 1280 × 1024 SXGA
Storage media	Depends on the PC's specifications.	Integrated storage device (SSD: 60 GB) External USB storage device PC connected to a network
Controller interface	USB3.1 Gen1	Display output: 2 x HDMI
		I/F: 4 x USB3.1 Gen1
		Wired LAN: 2 x LAN (1000BASE-T/100BASE-TX/10BASE-T)
		Serial port: RS-232C
		Audio: mic. input (monaural), phone jack
Scale bar	Supported	Supported
Measuring function	According to PRECiV software's specifications.	Measurement function count, distance between 2 points, polyline, 3-point circle, rectangle, 3-point angle, 4-point angle, perpendicular, area and perimeter of polygon, distance between 2 centers, ruler
DP23 Specifications	PC connection* <sup>2</sup>	Stand-alone* <sup>3</sup>
Maximum Recording Pixel	3088 x 2076 Full Resolution	
Live image display (frame rate) * <sup>1</sup>	45 fps (3088 × 2076 (full resolution))	30 fps (3088 × 2076 (full resolution))
	58 fps (2072 × 2072 (square))	43 fps (2072 × 2072 (square))
	59 fps (1544 × 1038 (sub-sampling 2 × 2—high speed))	59 fps (1544 × 1038 (sub-sampling 2 × 2—high speed))
	59 fps (1544 × 1038 (binning 2 × 2—high sensitivity))	59 fps (1544 × 1038 (binning 2 × 2—high sensitivity))
	60 fps (1920 × 1080 (full HD))	60 fps (1920 × 1080 (full HD))
Compatible image display	Depends on the PC's specifications	3840 × 2160 4K UHD TV, 2560 × 1440 WQHD, 1920 × 1200 WUXGA, 1920 × 1080 FHD, 1680 × 1050 WSXGA+, 1440 × 900 WXGA+, 1366 × 768 FWXGA, 1280 × 854 HDTV (720 p), 1600 × 1200 UXGA, 1280 × 1024 SXGA
Storage media	Depends on the PC's specifications	Integrated storage device (SSD: 60 GB) External USB storage device PC connected to a network
Controller interface	USB3.1 Gen1	Display output: 2 x HDMI
		I/F: 4 x USB3.1 Gen1
		Wired LAN: 2 x LAN (1000BASE-T/100BASE-TX/10BASE-T)
		Serial port: RS-232C
		Audio: mic. input (monaural), phone jack
Scale bar	Supported	Supported
Measuring function	According to PRECiV software's specifications.	Measurement function count, distance between 2 points, polyline, 3-point circle, rectangle, 3-point angle, 4-point angle, perpendicular, area and perimeter of polygon, distance between 2 centers, ruler

\*1 Frame rate depends on the condition of your PC and/or software. \*2 When using PRECiV \*3 When using DP2-AOU

# Specifications

## DP75 Specifications

Camera type		Single-chip color camera (pixel shifting) Cooling system: Peltier device (active cooling)
Imaging sensor size		1.1-inch, 12.37-megapixel color CMOS image sensor, global shutter
Camera mount		C-mount
Effective image resolution		8192 × 6000 (pixel shifting), 4096 × 3000 (3CMOS mode), 4096 × 3000 (1 × 1), 2048 × 1500 (2 × 2), 1920 × 1080 (1 × 1), ROI
Sensitivity		1x/2x/4x/8x/16x/32x (ISO 100/200/400/800/1600/3200 equivalent)
A/D		12-bit
Metering modes	Mode	Auto / SFL-Auto / Manual
	Adjustment	±2.0 EV step: 1/3 EV
	Time	28 μs–120 s
Binning		2 × 2
White balance		Manual/Area designation
Black balance		Manual/Area designation
Live frame rate *1		4096 × 3000 (1 × 1): 22 fps, 2048 × 1500 (2 × 2): 22 fps, 1920 × 1080 (1 × 1): 60 fps
Still image transfer time		8192 × 6000 (pixel shifting): approx. 3 s, 4096 × 3000 (3CMOS Mode): approx. 2 s, 4096 × 3000 (1 × 1): approx. 1.2 s, 2048 × 1500 (2 × 2): approx. 1.0 s, 1920 × 1080 (1 × 1): approx. 0.4 s
Monochrome mode		Available (Standard/Custom )
Color space		sRGB, AdobeRGB*2
IR cut filter		Switchable: In: 400 nm up to 650 nm Out: 400 nm up to 1000 nm
Manual panoramic imaging (instant MIA)*3		Available
Position navigator*3*4		Available
Control software		PRECiV v. 2.1 or later DP2-TWAIN v. 10.4 or later
External trigger		Available (input/output)
Dimensions (W × D × H)	Camera interface cable	Approx. 2.7 m (8.9 ft)
	AC adapter	107 × 47 × 30 mm (4.2 × 1.9 × 1.2 in.)/Approx 0.3 kg (0.7 lb)

\*1 Frame rate may decrease depending on the condition of your PC, monitor resolution, and/or software.

\*2 Monitor designed to meet Adobe RGB is required.

\*3 Not available in the combination of DP2-TWAIN.

\*4 Not available in the combination of PRECiV Capture.

• **EVIDENT CORPORATION is ISO14001 certified.**  
For details on certification registration, visit <https://www.olympus-ims.com/en/iso/>

• **EVIDENT CORPORATION is ISO9001 certified.**

• All company and product names are registered trademarks and/or trademarks of their respective owners.  
• Specifications and appearances are subject to change without any notice or obligation on the part of the manufacturer.  
• Microsoft and Windows are registered trademarks of Microsoft Corporation in U.S. The terms HDMI and HDMI High-Definition Multimedia Interface, and the HDMI Logo are trademarks or registered trademarks of HDMI Licensing Administrator, Inc. in the United States and other countries. The SuperSpeed USB 5Gbps Trident Logo is a registered trademark of USB Implements Forum, Inc.

[EvidentScientific.com](https://www.evidentscientific.com)



**EVIDENT**

EVIDENT CORPORATION  
Shinjuku Monolith, 2-3-1 Nishi-Shinjuku, Shinjuku-ku, Tokyo 163-0910, Japan

**OLYMPUS**