

EVIDENT



OLYMPUS

Motorized Nosepiece

+

+

Precision Made Simple

DSX2000

Digital Microscope

+

+

FRONT

STAGE ROTATION

XY ALIGNMENT

CENTER ADJUSTMENT

Advanced Microscopy Designed for Every User

Precision Meets Simplicity

The DSX2000 digital microscope series simplifies tasks, boosts productivity, and streamlines work for researchers and QC lab professionals with smart tools, all-in-one imaging, and a customizable interface.

The DSX2000 microscope series with PRECiV™ software empowers your team to achieve fast, precise results and capture exceptional images. An intuitive, seamless experience enables users of all skill levels to operate the system with ease and confidence.



DSX2000 Digital Microscope Series

Choose Your Model

The DSX2000 digital microscope series includes motorized, universal, or standard zoom head options so you can customize the system to your exact imaging and workflow needs. Whether your team needs full automation, advanced functionality, or just the basics, the DSX2000 series has you covered.



Fully Motorized DSX2000 MZH

Full motorization simplifies tasks and boosts productivity so your team can navigate challenges with ease. The motorized zoom head with an automatic revolving nosepiece supports up to four objective lenses for effortless magnification changes and seamless macro to micro inspections. This model is ideal for high-resolution observations and inspection applications requiring efficient go/no-go decisions.



Versatile All-in-One DSX2000 UZH/SZH

Our universal and standard zoom head models enable seamless macro to micro inspections with a single system. The sliding nosepiece supports up to two objective lenses for seamless magnification changes. These models offer the flexibility to use a wide variety of objective lens types, including super long working distance options, and to image your sample from a wide range of angles.

Simplify Operations with an All-in-One Solution

See the Whole Picture

The DSX2000 microscope series offers a wide magnification range of 21X–7,300X, enabling you to complete macro and micro inspections with one system. With a lineup of 20 objective lenses, including super long working distance and high-resolution options, you can easily adapt your imaging to different samples and applications.



Fast and Flexible Macro Imaging

Quickly capture overview images of samples with the macro camera. This flexible accessory can be detached and held by hand to image large samples that cannot be placed on the stage. Switching to the macro camera view in the software is simple, making it easy to alternate between micro and macro imaging. Generate comprehensive reports faster with the required overview and magnified images.



Macro image of sample

Switch Objectives Quickly and Easily

Quickly and easily change objectives on any DSX2000 model. The easy-to-replace lenses and adjustable settings in an ergonomic system let you work faster and maintain comfort.

Switch Automatically

For systems with a motorized zoom head, you can control the automatic revolving nosepiece from either the console or your computer to make effortless magnification changes.

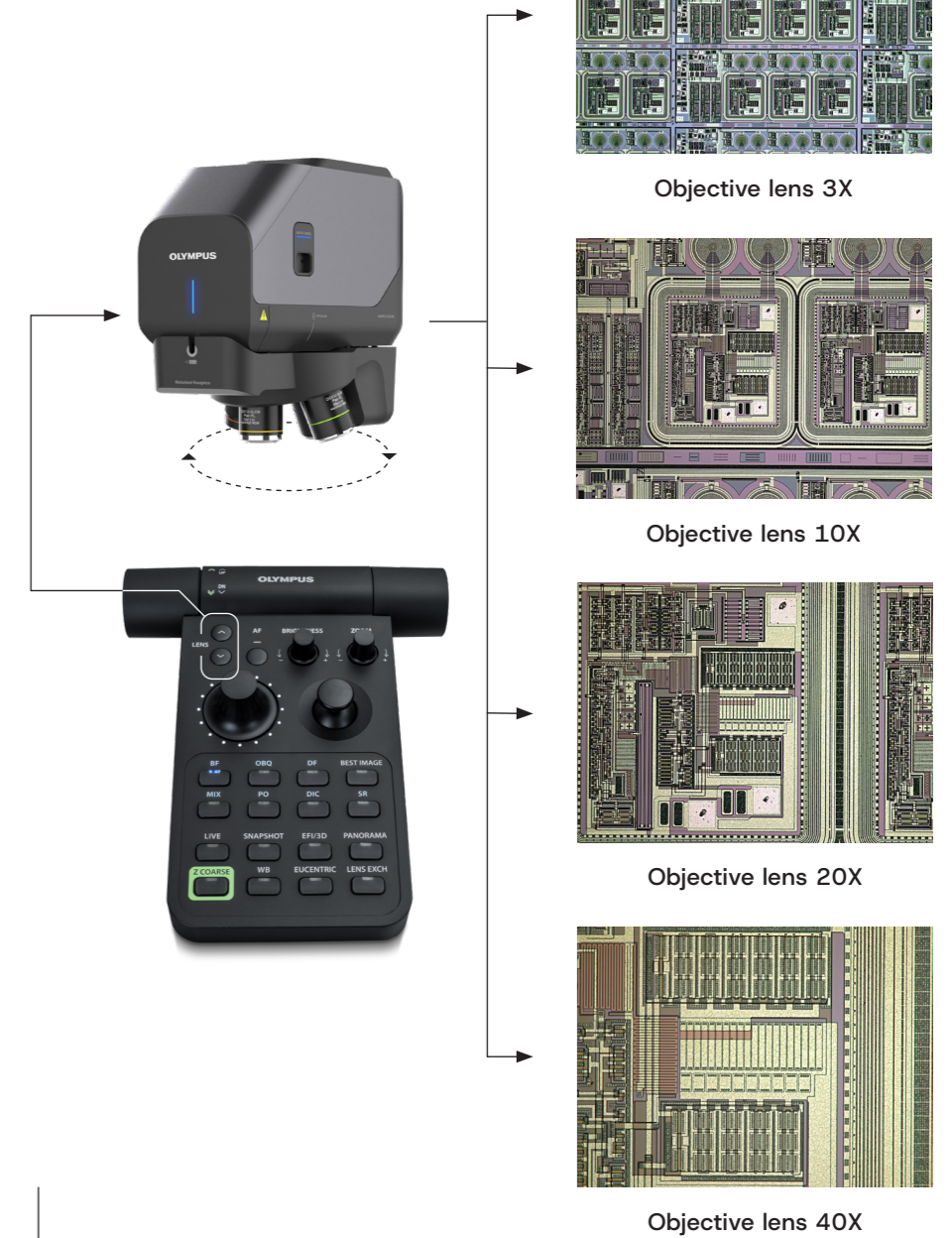

Switch with a Slider

Systems with standard or universal zoom heads also offer seamless magnification changes via the sliding nosepiece, where up to two objective lenses can be attached at the same time. Switch the magnification just by sliding the lens for fast macro to micro imaging. This system makes it easy to change lens types, providing flexibility for various inspection needs.



Simplify Operations with an All-in-One Solution

See What Matters with One Click

The DSX2000 microscope offers seven different observation methods at the click of a button. Find viewing conditions using brightfield (BF), oblique (OBQ), darkfield (DF), MIX (DF and BF), polarization (PO), differential interference contrast* (DIC), or our unique shaded relief (SR) method.

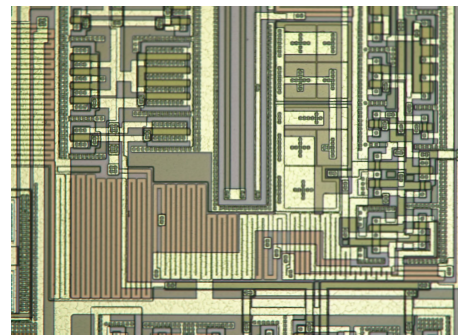

BF Brightfield

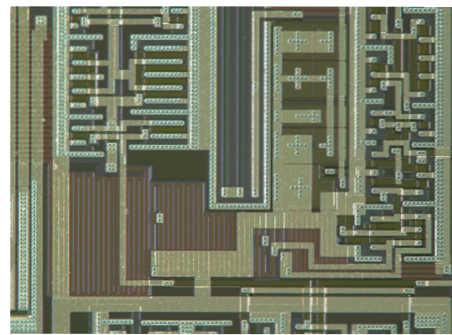

MIX Brightfield + Darkfield

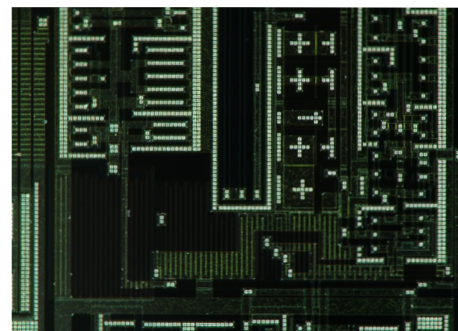

PO Polarization

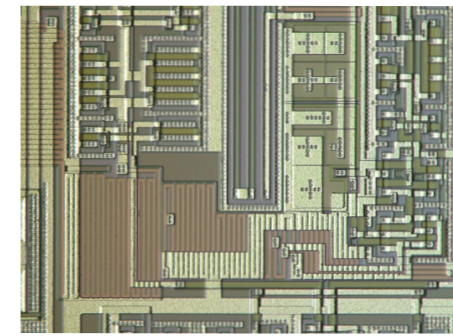

OBQ Oblique

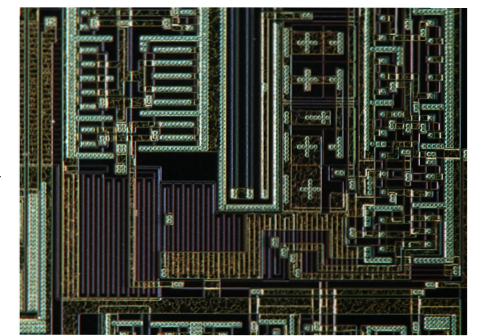

DF Darkfield

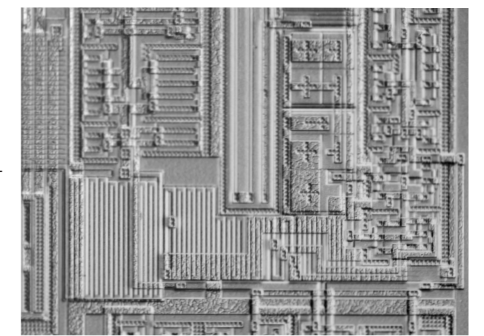

SR Shaded relief

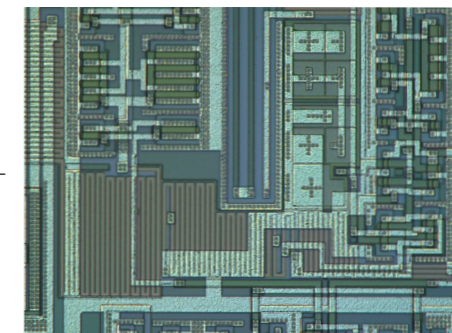

DIC Differential interference contrast

BF Brightfield

SR Shaded relief

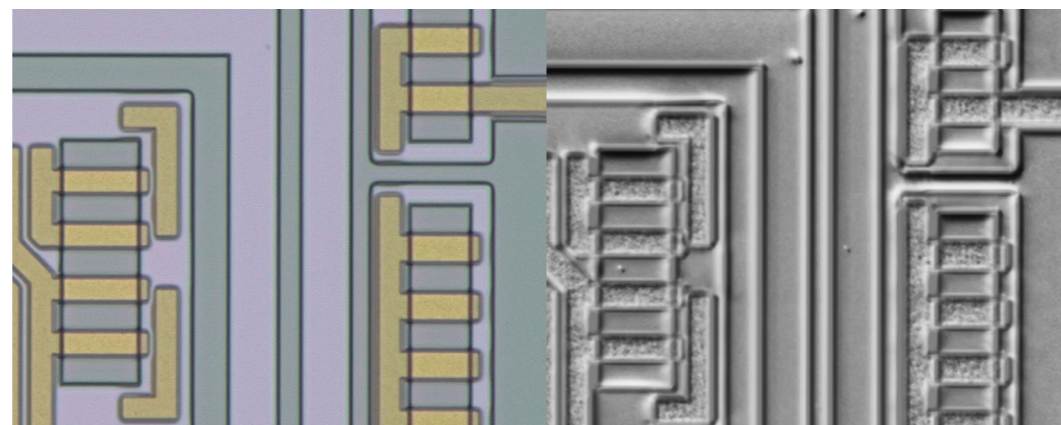

Shaded Relief Observation Mode

Reveal ultra-fine, hard-to-see defects in real time, without post-processing delays. Move the stage and scan your sample seamlessly, viewing shaded relief images instantly for fast, thorough inspections.

* Not available on the SZH model.

Simplify Operations with an All-in-One Solution

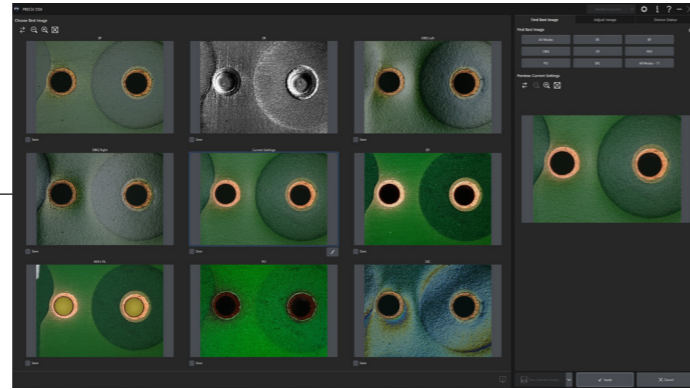

Find the Best Image, Fast

The best image function reviews all available observation methods for your sample and identifies the best imaging mode for revealing what needs to be seen—all with a simple click.

Lighting Tailored to Your Sample

Observe internal details in transparent, semi-transparent, or thin samples with a variety of transmitted lighting and contrast options. Simply select cartridges according to the type and purpose of the sample.

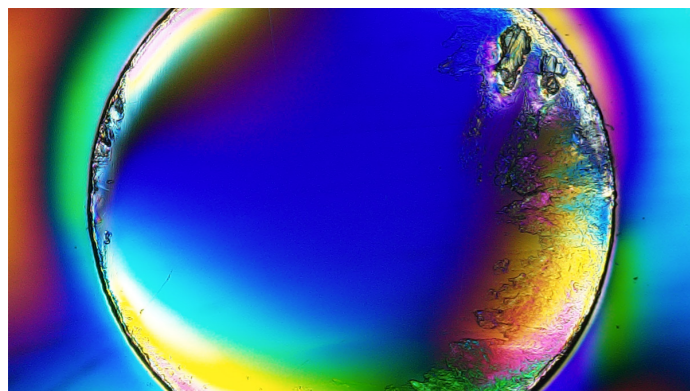

Plastic molded product Polarization

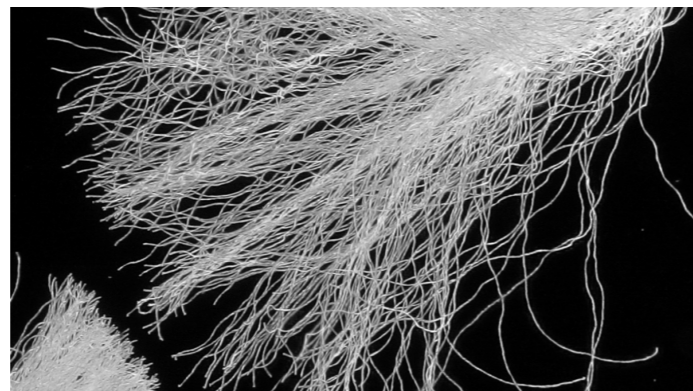

Fibers Darkfield

Adaptable Sample Positioning

The extended stage (up to 200 × 100 mm) accommodates multiple or large samples, while the tilting frame and rotating stage enable you to place your sample in the best observation conditions.



Tilting frame



Rotational stage

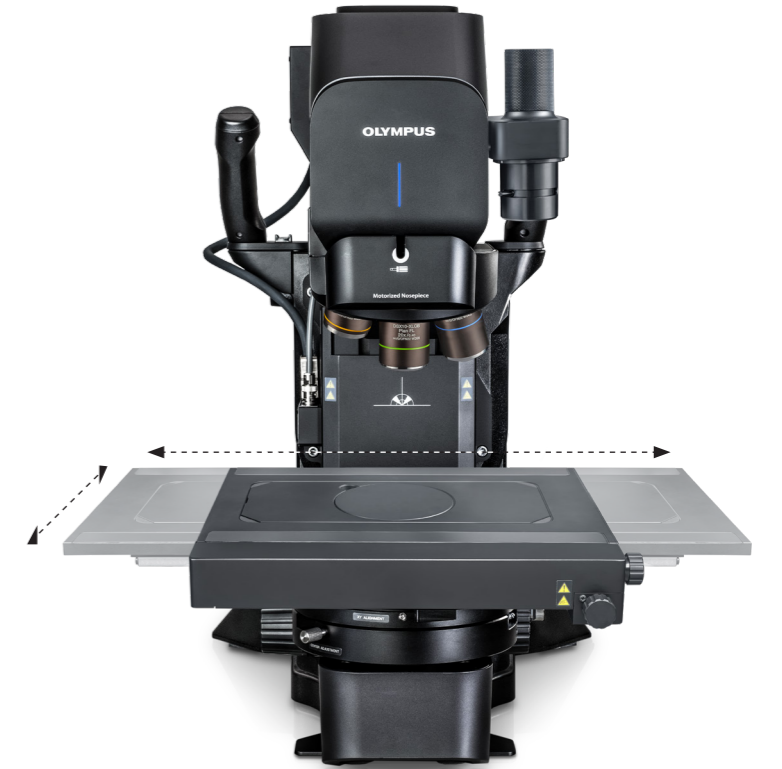

Extended Stage

Improve Productivity with Smart Tools

Customized Workflows for Faster Operation

EZ

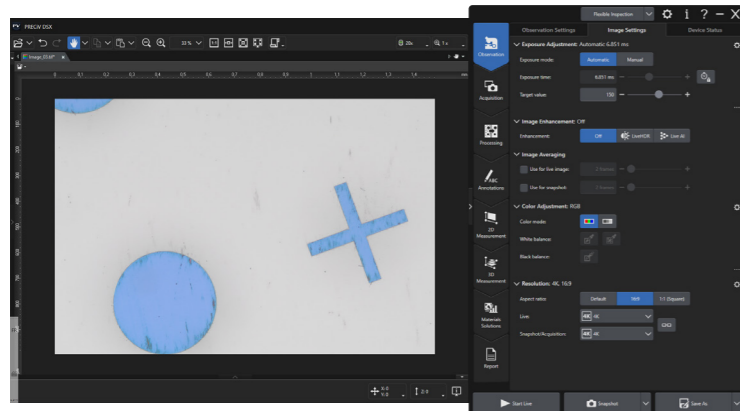

Define your workflow

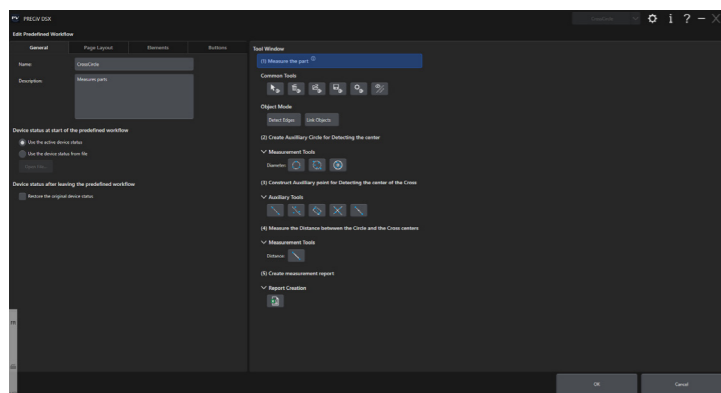

Arrange the icons

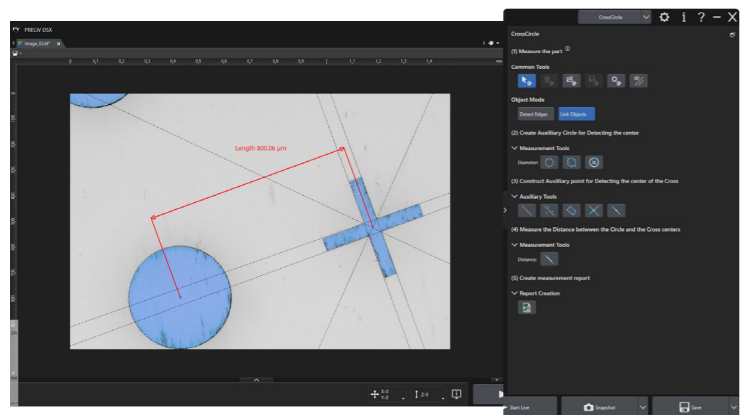

Activate the workflow

The Power to Work Smarter

Customized workflows and AI capabilities on the DSX2000 digital microscope give you the power to work smarter, unlocking more efficient ways to perform routine inspections or conduct complex analyses.

Automate Repetitive Tasks
Automate live measurements, edge detection, and other repetitive processes, minimizing operator input and variability while speeding up inspections.

Collect Data Quickly
Powerful interactive measurement tools include edge-detected circles, magic wand, auxiliary lines, object linking, and more.

EZ mode simplifies the interface by displaying only essential functions. Supervisors can create custom workflows for operators, limiting available buttons for consistency and ease of use. Operators can get to work quickly with minimal training while reducing the potential for errors.

Unlock Efficiency with AI

PRECiV™ image analysis software equips all Evident industrial microscopes—including the DSX2000 system—with our unique Live AI.

This powerful tool instantly reveals hidden details and highlights key features on live images without the need for additional processing.

AI-assisted decision-making frees your experts from the need to double-check images.

AI

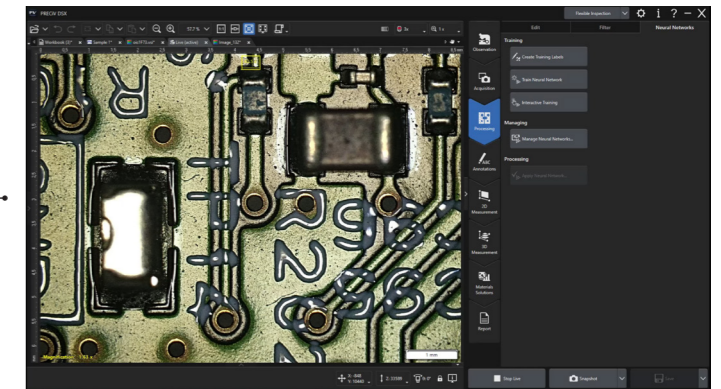

Live image

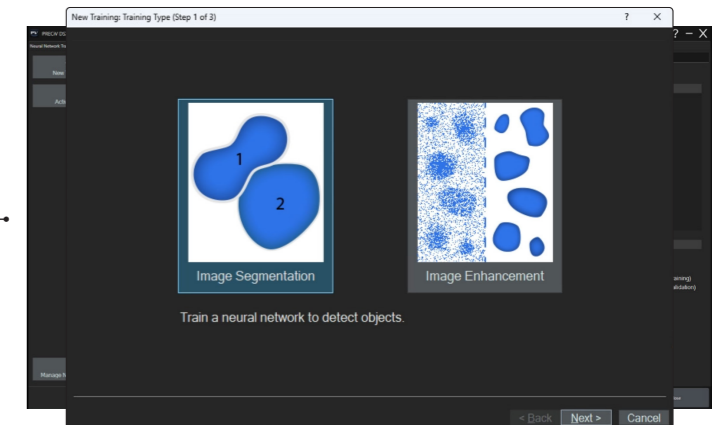

Train the neural network (5 minutes)

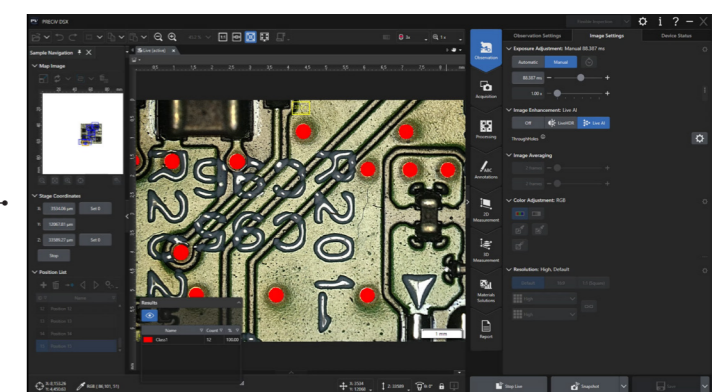

Apply the neural network to the live image

Improve Productivity with Smart Tools

Simplify Your Technical Cleanliness

Cleanliness is critical in manufacturing. Micron-sized contaminants can cause failures, so today's standards require clear insight into particle count, size, and characteristics. With PRECiV™ ADM* software, the DSX2000 delivers these particle insights in one easy-to-use platform. Compliant results are customized to company and industry standards, including ISO 16232 and VDA 19, in just one click.

*PRECiV ADM is only available on the MZH model.

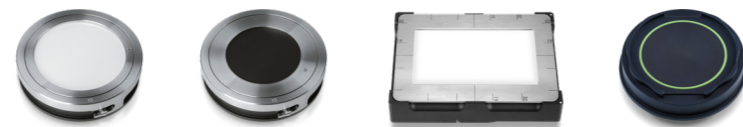
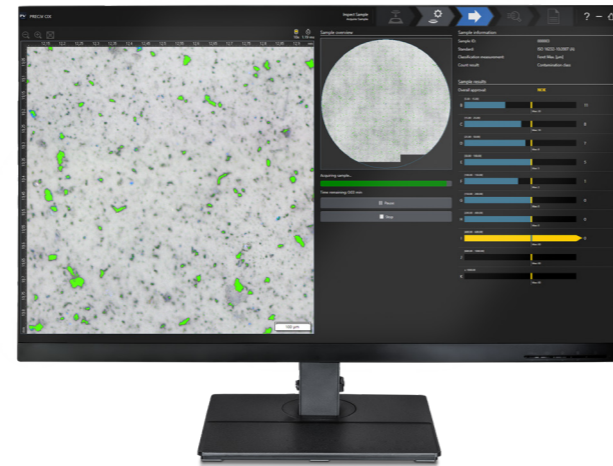

Guided Cleanliness Analysis Workflow

The DSX2000 is a turnkey solution designed to meet the needs of automated technical cleanliness inspection. Optimized imaging, precise detection, and guided steps deliver accurate, repeatable results while reducing manual effort and contamination risk.



Intuitive, easy-to-click workflow steps: Mount Sample → Edit Settings → Run Inspection → Review Results → Create Report.



Selecting a thumbnail automatically drives the system to this contaminant.

Review Particle Results with Confidence

Fast, intuitive particle review is supported by one-click reclassification and linked thumbnail images with measurements. Updates apply automatically across all views, delivering clear, consistent results with less effort.

Versatility for Common Sampling Methods

A range of holders supports circular and rectangular inspection areas, including options for different filter sizes, tape lift samples, flat metallurgy surfaces, and particle traps.



Circular sample holders with white and black backgrounds for filter membranes with diameters of 25 mm (top), 47 mm (middle), and 55 mm (bottom).

Sample holder for particle traps

Sample holder for tape lift sampling*

*Availability of the tape lift holder may vary by region.



Improve Productivity with Smart Tools

Simplify Tasks with Unified Software

PRECiV™ software operates the same way on all our industrial microscopes, creating a cohesive analysis environment. Access tools for 2D/3D measurements, image enhancement, macro recording, AI-assisted analysis, and more.

Maximize Throughput

Analyze images on any PC equipped with PRECiV software. This frees up the DSX2000 microscope for image acquisition, increasing workflow efficiency.

Easier Imaging, Measurement, and Analysis

Access tools for 2D/3D measurements, image enhancement, macro recording, AI-assisted analysis, and more.

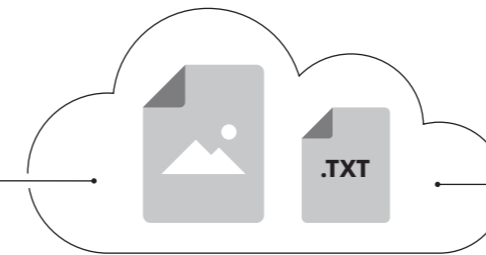
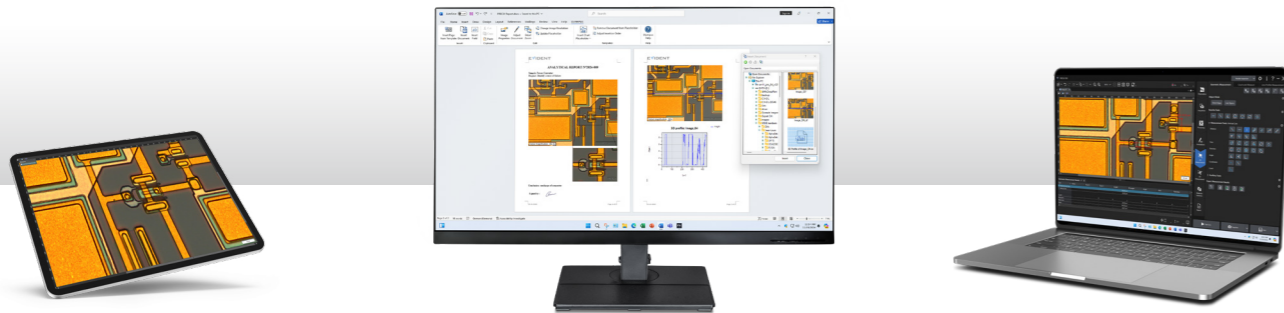
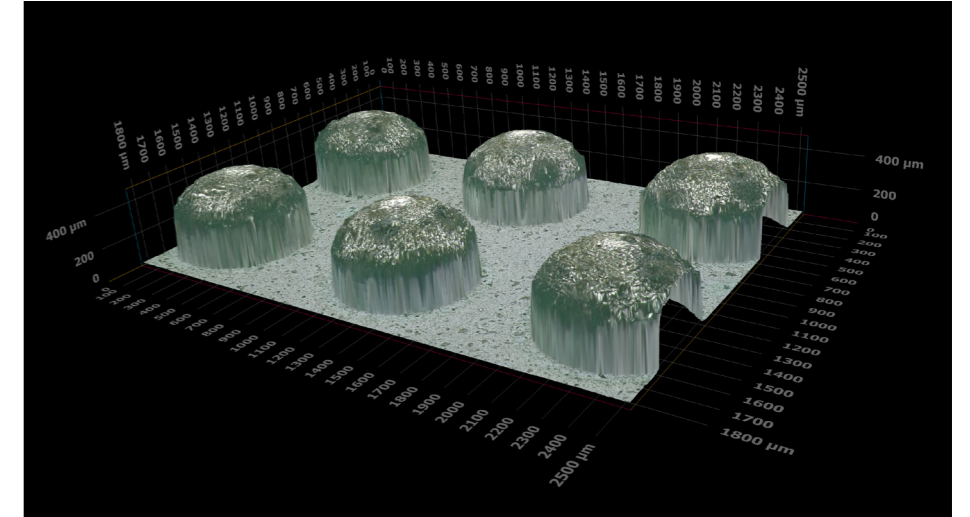

Create Compliant Reports Easily

When it's time to present your results, the DSX2000 microscope makes reporting easy. Use the plug-in for Microsoft 365 to design your own reports in Microsoft Word, Excel, or PowerPoint.

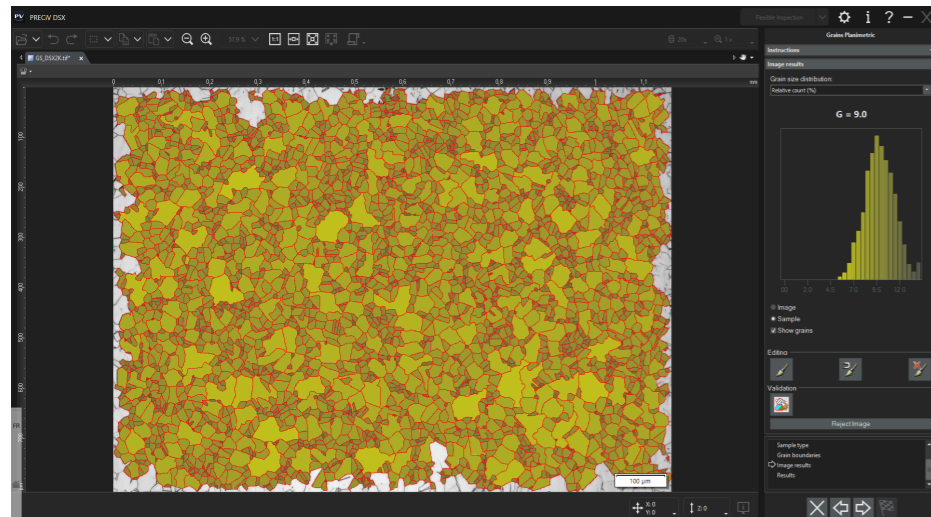

Compliant Measurements in a Few Clicks

Simplify daily tasks for material analyses with standard-compliant automated workflows. Choose from options for grain sizing, cast iron analysis, phase analysis, non-metallic inclusion rating, and more.

Seamless Network Integration

Easily connect the DSX2000 microscope to your company network for IT compliance and quick image sharing.

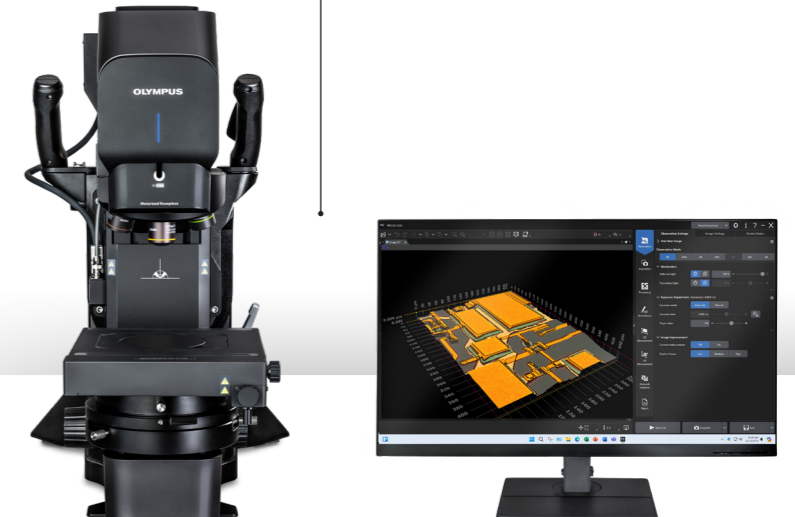

Assurance in Your Images and Measurements

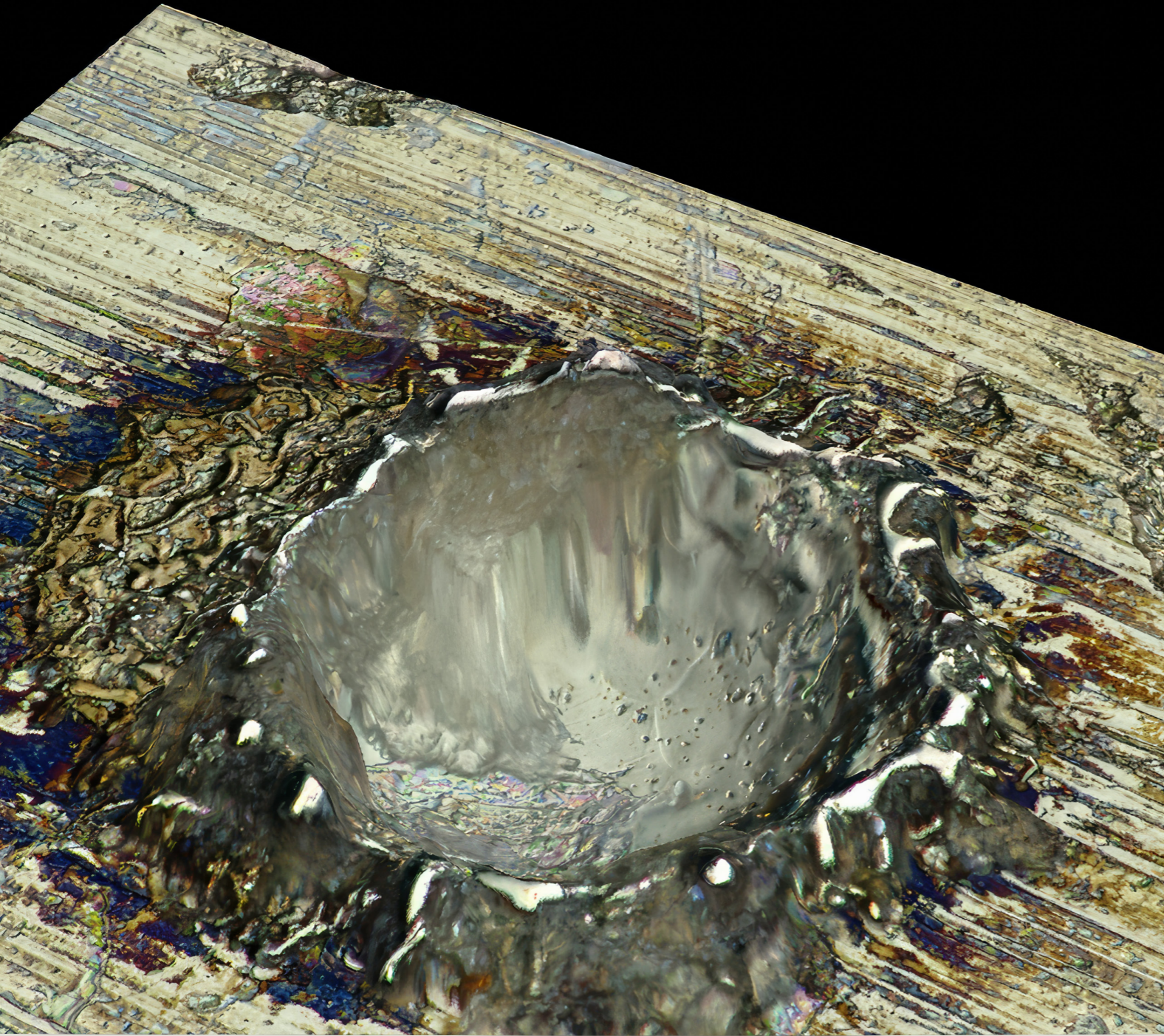

Confidence in Every Detail

Be confident in your results knowing that the DSX2000 digital microscope produces exceptional images and precise measurements that meet the exacting demands of quality control, failure analysis, and R&D.

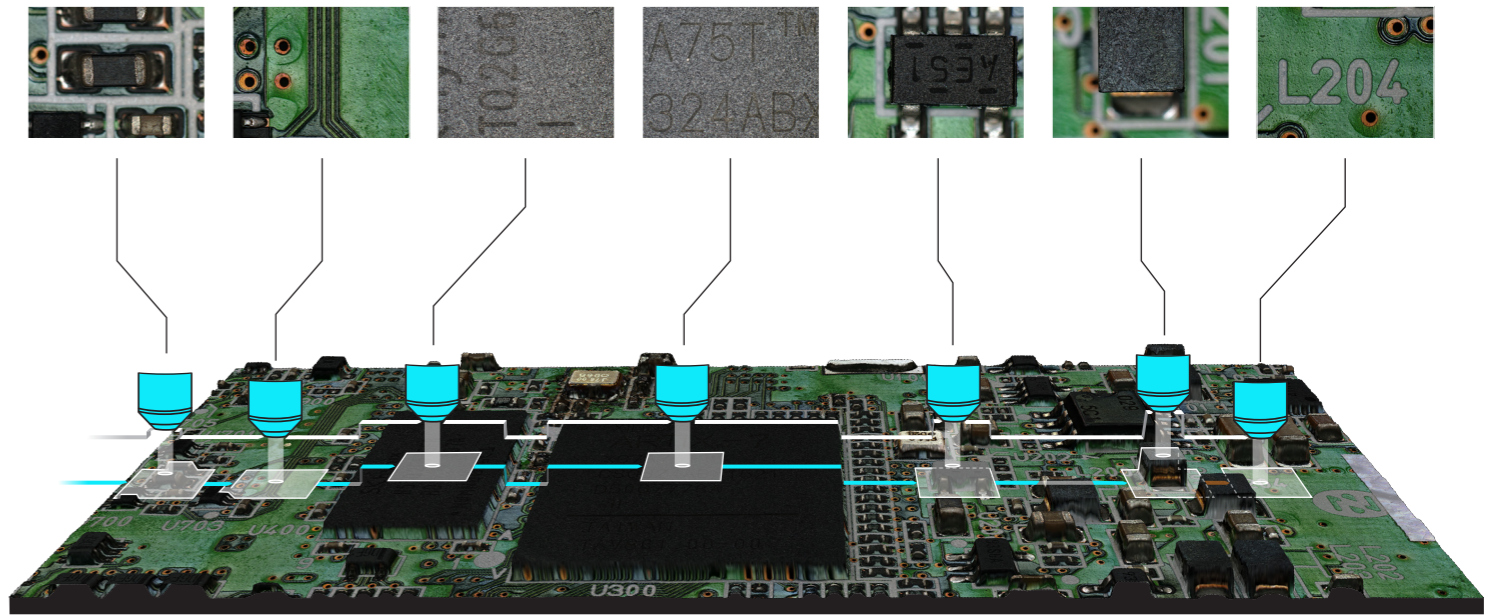

Continuous Autofocus

The objective lens automatically moves up and down to match the unevenness of the object, providing a live image that is always in focus even when the observation location changes. By eliminating the need to adjust focus manually, the DSX2000 microscope helps your lab improve analysis and inspection efficiency.

High-Resolution Imaging Beyond 4K

The DSX2000 microscope empowers inspections with image quality that surpasses standard 4K resolution*, delivering enhanced clarity and coverage across sample types—whether large, thin, thick, rough, reflective, or transparent. Pair the system with, for example, a 32-inch 4K monitor, to further enhance sample details for observation and analysis.

* Resolution beyond 4K is not available on the SZH model.

HD

Full High Definition Mode

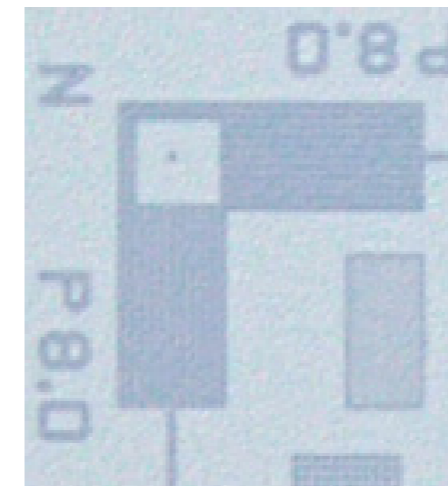

4K

4K Mode

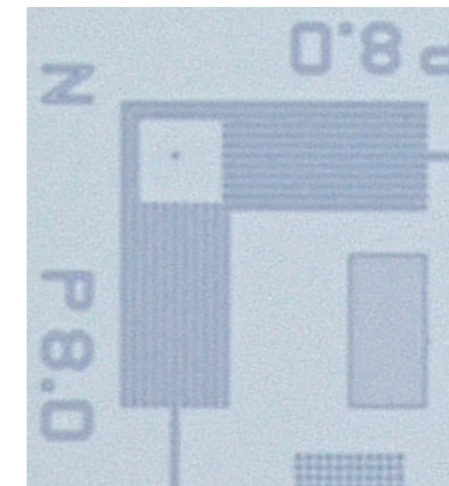

8K

Ultra Mode

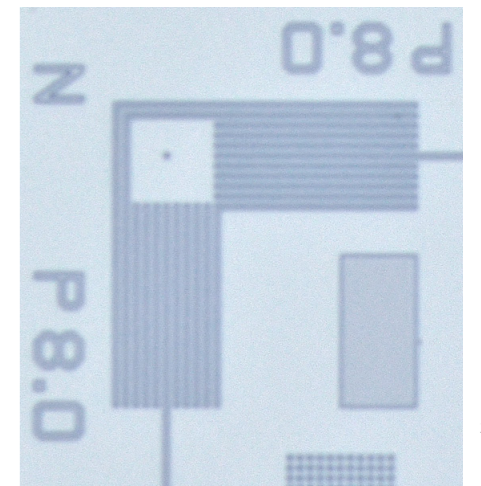

Assurance in Your Images and Measurements

Unlimited Image Size

Seamless stitching quickly creates large macro images, enabling analysis of large samples in less time. Create macro images as large as you want—the only limits are your hard drive space and stage travel range.

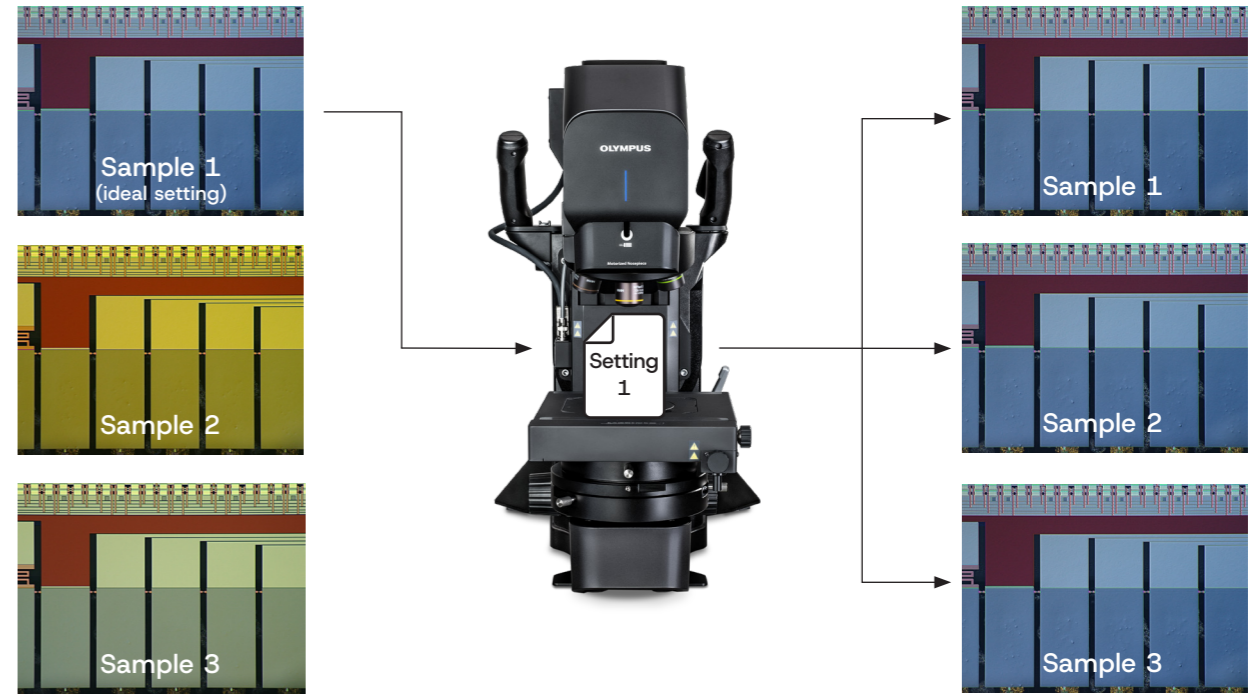
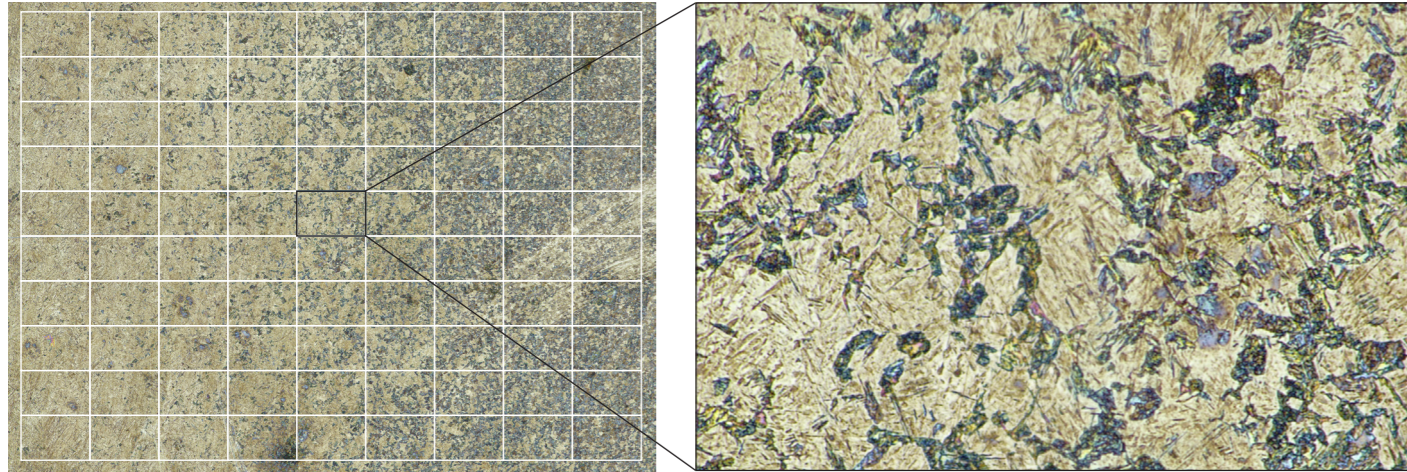

Save and Recall Observation Conditions

Captured images automatically record their settings, so you can easily recall and reuse conditions with a single click for consistency and repeatability.

Advanced 3D Measurements

Get detailed insights into surface heights and features with precise 3D analysis for complex inspections.

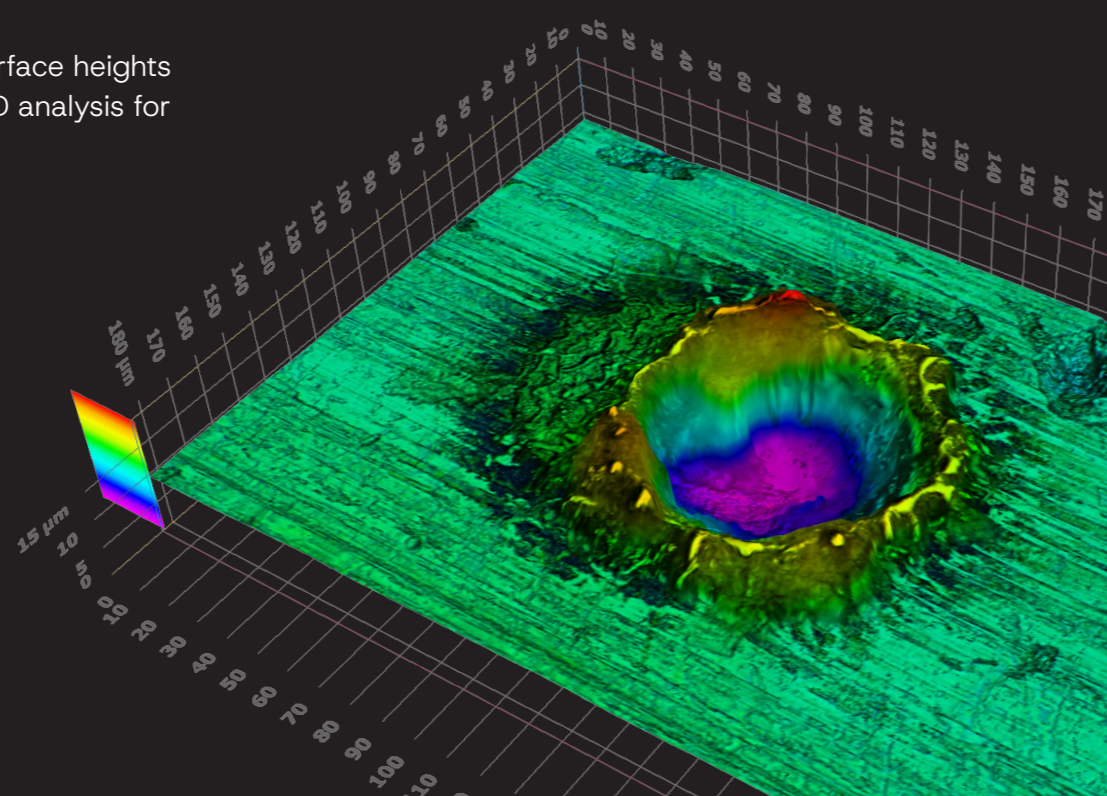

Guaranteed* Accuracy and Repeatability

Telecentric optics and traceable, time-stamped calibration from Evident technicians provide precision and easy alignment with your metrology standards.

* The guaranteed accuracy and repeatability apply only if the device has been calibrated according to the manufacturer's specifications and is in defect-free condition. Calibration must be performed by an Evident technician or an Evident-authorized specialist.

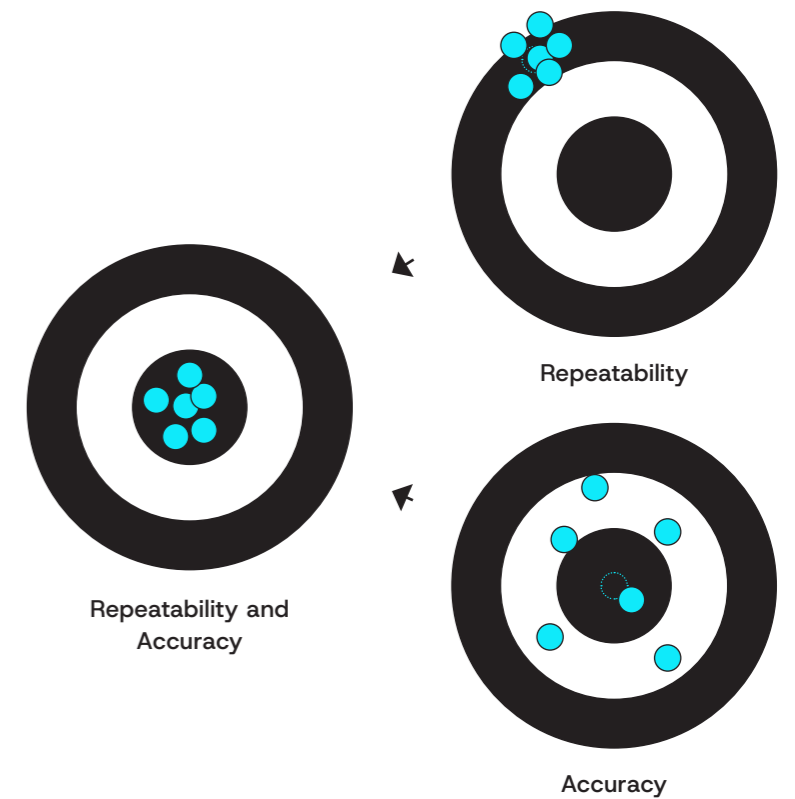

Integrated Observation Methods

Easily switch between brightfield (BF), oblique (OBQ), darkfield (DF), MIX (BF and DF), simple polarization (PO), differential interference contrast (DIC), and shaded relief (SR). This flexibility enables you to handle almost any microscope inspection task.

BF
Brightfield
Good for flat samples

On a mirrored surface, scratches look dark against the surface, helping them stand out.



OBQ
Oblique
Enhance your surface's unevenness

Use this method to enhance a surface's unevenness by shining the light from only one direction. This method is ideal for uneven or corrugated samples and cutting traces.

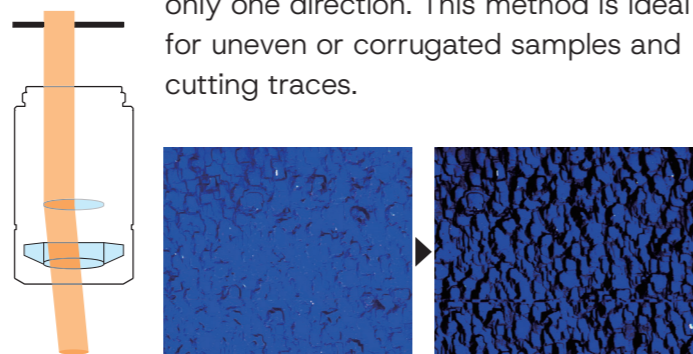

PO
Polarization
Designed for polarizing samples

By orthogonally laying out two polarization filters, this method enables you to see the contrast and color according to your sample's polarization property.

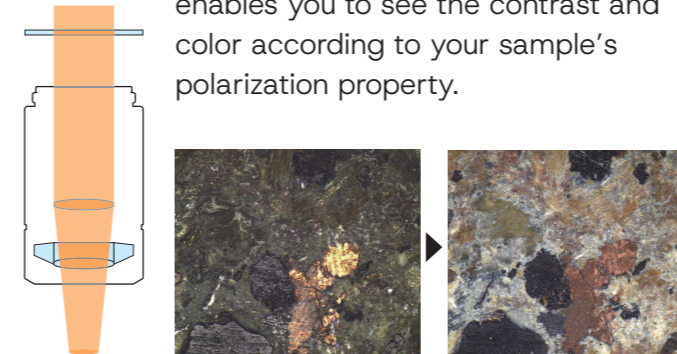

DIC
Differential Interference Contrast
Enhance your surface's unevenness

Use this method to enhance a surface's unevenness by shining the light from only one direction. This method is ideal for uneven or corrugated samples and cutting traces.

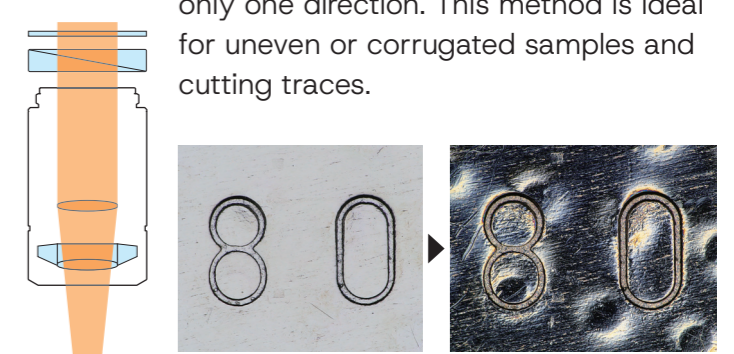

DF
Darkfield
For scratches and similar defects

Scattering or reflected light is obliquely irradiated on the sample's surface, highlighting dust, scratches, and other objects. Dust and scratches appear bright in the visual field.

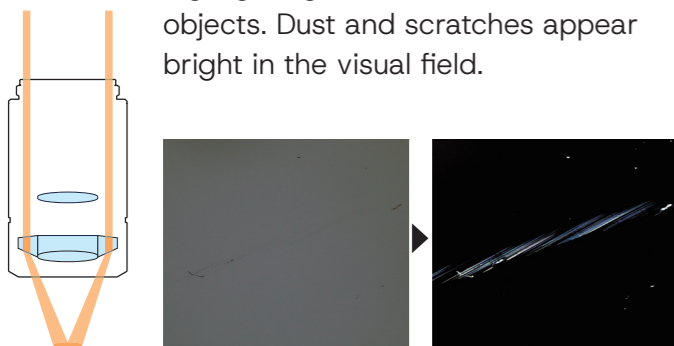

MIX
BF+DF
Light comes from around the lens

Easily detect scratches and defects that can be hard to find with a conventional microscope by combining the detection capabilities of darkfield (DF) to the visibility of brightfield (BF).

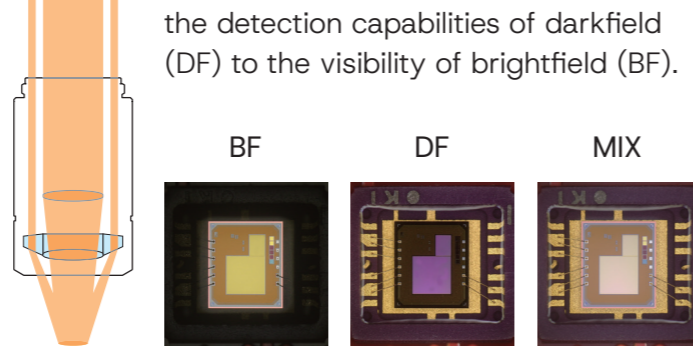

SR
Shaded Relief
Reveal defects in real time

Illuminates the sample from different directions, revealing defects as the image is created in real time. Fine surface details are highlighted through shading, enabling clear observation for fast, thorough inspections.

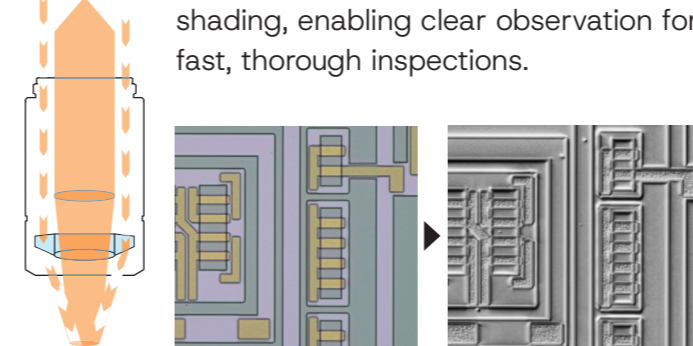

Integrated Observation Methods

Objective Lenses

		20X	40X	100X	200X	500X	1,000X	3,000X	6,000X	10,000X	Working Distance (mm)	NA	Field of View ¹ (μm)
Super long working distance objective lenses Provides a long working distance between the lens and sample 	DSX10-SXLOB1X ²	20.9–146.1X									51.7	0.03	18182 × 13317 μm 2597 × 1902 μm
	DSX10-SXLOB3X ²		43.8–438.4X								66.1	0.09	8658 × 6341 μm 866 × 634 μm
	DSX10-SXLOB10X ²			146.1–1,461X							41.1	0.20	2597 × 1902 μm 260 × 190 μm
High-resolution, long working distance objective lenses Delivers both high resolution and a long working distance 	DSX10-XLOB3X ²		43.8–438.4X								30.0	0.09	8658 × 6341 μm 866 × 634 μm
	DSX10-XLOB10X			146.1–1,461X							30.0	0.30	2597 × 1902 μm 260 × 190 μm
	DSX10-XLOB20X			292.3–2,923X							20.0	0.40	1299 × 951 μm 130 × 95 μm
	DSX10-XLOB40X			584.5–5,845X							4.5	0.80	649 × 476 μm 65 × 48 μm
High-performance, high NA objective lenses Delivers high performance at the nano scale 	MPLFLN1.25X ⁴	26.1–182.7X									3.5	0.04	14546 × 10654 μm 2078 × 1522 μm
	MPLFLN2.5X ⁴	39.1–365.3X									10.7	0.08	9697 × 7102 μm 1039 × 761 μm
	MPLFLN2.5XBD ⁵	39.1–365.3X									8.7	0.08	9697 × 7102 μm 1039 × 761 μm
	MPLFLN5XBD	73.1–730.7X									12.0	0.15	5195 × 3805 μm 519 × 380 μm
	MPLFLN10XBD	146.1–1,461X									6.5	0.30	2597 × 1902 μm 260 × 190 μm
	MPLFLN20XBD	292.3–2,923X									3.0	0.45	1299 × 951 μm 130 × 95 μm
	MPLFLN50XBD	730.7–7,307X									1.0	0.80	519 × 380 μm 52 × 38 μm
	MPLAPON50X ³	730.7–7,307X									0.35	0.95	519 × 380 μm 52 × 38 μm
	LMPLFLN10XBD	146.1–1,461X									10.0	0.25	2597 × 1902 μm 260 × 190 μm
	LMPLFLN20XBD	292.3–2,923X									12.0	0.40	1299 × 951 μm 130 × 95 μm
LMPLFLN50XBD	730.7–7,307X									10.6	0.50	519 × 380 μm 52 × 38 μm	
MXPLFLN20XBD	292.3–2,923X									3.0	0.55	1299 × 951 μm 130 × 95 μm	
MXPLFLN50XBD	730.7–7,307X									3.0	0.80	519 × 380 μm 52 × 38 μm	

¹ Magnification and field of view are based on a 27-inch 4K monitor, scale setting: 175%, anti-vibration mode: off, fit to window mode, image aspect ratio: 4:3.

² The DSX10-SXLOB1X, 3X, 10X, and DSX10-XLOB3X do not support PO observation.

³ The MPLAPON50X does not support DF, MIX, or SR observations.

⁴ The MPLFLN1.25X and 2.5X do not support DF, MIX, PO, DIC, or SR.

⁵ The MPLFLN2.5XBD does not support PO or DIC observations.

DSX2000 System Chart

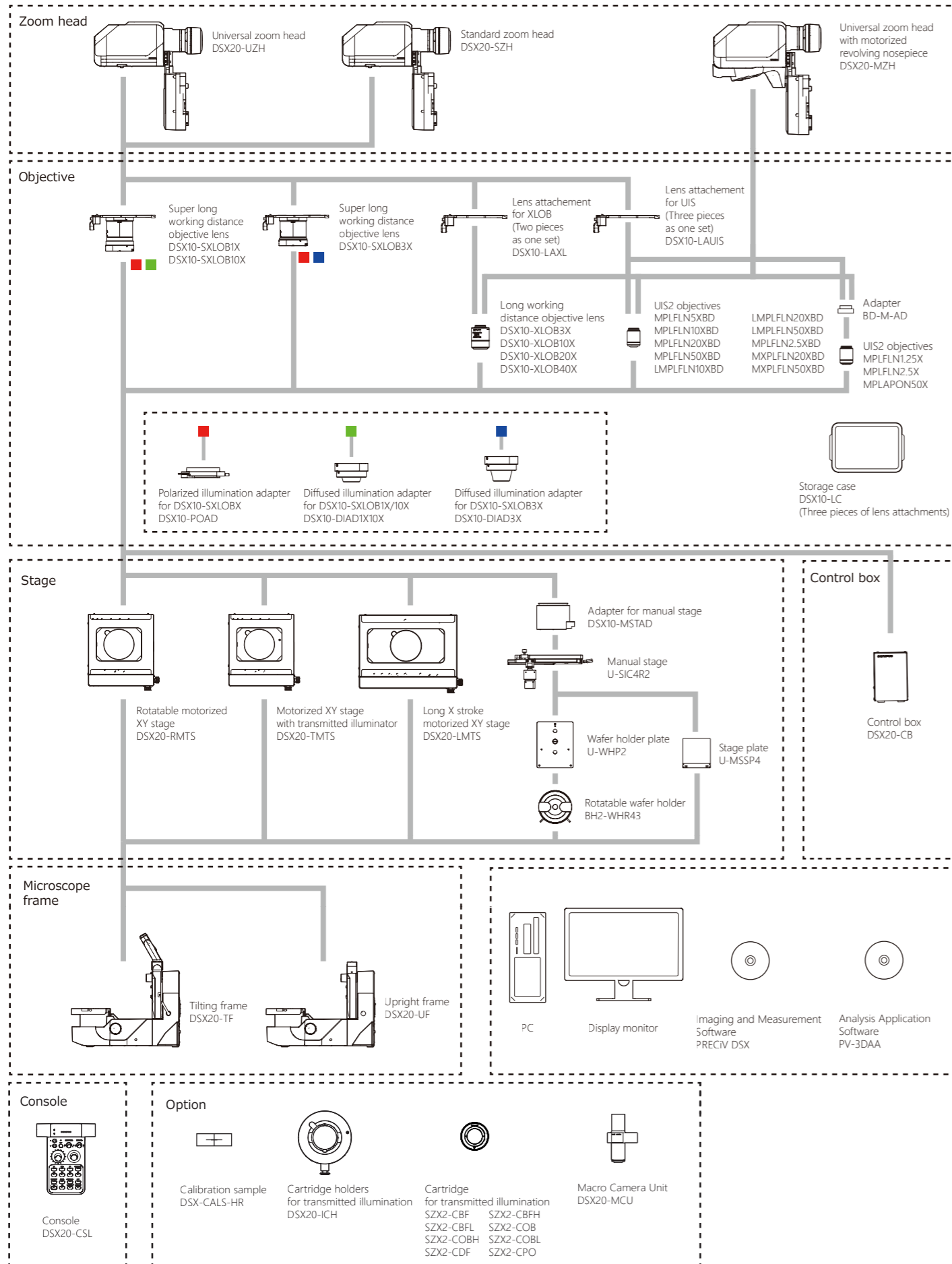

DSX2000 Specifications

		Standard (DSX20-SZH)	Universal (DSX20-UZH)	Motorized (DSX20-MZH)	
Zoom head	Optical system	Telecentric optical system	Telecentric optical system	Telecentric optical system	
	Optical zoom ratio	From 1X to 10X	From 1X to 10X	From 1X to 10X	
	Optical zoom magnification method	Motorized	Motorized	Motorized	
	Calibration	Automatic	Automatic	Automatic	
	Nosepiece	Manual sliding nosepiece	Manual sliding nosepiece	Motorized revolving nosepiece	
	Number of objectives that can be attached	Up to 2 objectives	Up to 2 objectives	Up to 4 objectives	
	Accuracy and repeatability (X-Y plane)	Accuracy ¹ Repeatability 3 σ -1	$\pm 3\%$ 2%	$\pm 3\%$ 2%	$\pm 3\%$ 2%
	Repeatability (Z axis) ²	Repeatability σ -1	1 μ m	1 μ m	1 μ m
	Camera	Image sensor	1.1-inch 12.37-megapixel color CMOS image sensor, global shutter	1.1-inch 12.37-megapixel color CMOS image sensor, global shutter	1.1-inch 12.37-megapixel color CMOS image sensor, global shutter
		Cooling	Peltier cooling	Peltier cooling	Peltier cooling
Frame rate		60 fps (maximum)	60 fps (maximum)	60 fps (maximum)	
Ultra (pixel shift mode)		Not available	6000 \times 6000 (1:1), 8192 \times 6000 (4:3)	6000 \times 6000 (1:1), 8192 \times 6000 (4:3)	
Super high (3CMOS mode)		Not available	3000 \times 3000 (1:1), 4096 \times 3000 (4:3)	3000 \times 3000 (1:1), 4096 \times 3000 (4:3)	
Super high		3000 \times 3000 (1:1), 4096 \times 3000 (4:3)	3000 \times 3000 (1:1), 4096 \times 3000 (4:3)	3000 \times 3000 (1:1), 4096 \times 3000 (4:3)	
4K mode		3840 \times 2160 (16:9) 1500 \times 1500 (1:1), 2048 \times 1500 (4:3)	3840 \times 2160 (16:9) 1500 \times 1500 (1:1), 2048 \times 1500 (4:3)	3840 \times 2160 (16:9) 1500 \times 1500 (1:1), 2048 \times 1500 (4:3)	
High		1500 \times 1500 (1:1), 2048 \times 1500 (4:3)	1500 \times 1500 (1:1), 2048 \times 1500 (4:3)	1500 \times 1500 (1:1), 2048 \times 1500 (4:3)	
High (binning 2 \times 2)		1500 \times 1500 (1:1), 2048 \times 1500 (4:3)	1500 \times 1500 (1:1), 2048 \times 1500 (4:3)	1500 \times 1500 (1:1), 2048 \times 1500 (4:3)	
Full HD mode		1920 \times 1080 (16:9)	1920 \times 1080 (16:9)	1920 \times 1080 (16:9)	
Illumination	Color light source	LED	LED	LED	
	Lifetime	60,000 h (design value)	60,000 h (design value)	60,000 h (design value)	
Observation	BF (brightfield)	Available	Available	Available	
	OBQ (oblique)	Available	Available	Available	
	DF (darkfield)	Available	Available	Available	
	MIX (brightfield + darkfield)	Available	Available	Available	
	PO (polarization)	Simultaneous observation of BF + DF	Simultaneous observation of BF + DF	Simultaneous observation of BF + DF	
	DIC (differential interference contrast)	Available	Available	Available	
	SR (shaded relief)	Available	Available	Available	
	Mechanical aperture for contrast settings	Available	Available	Available	
	Mechanical aperture for depth of focus	Not available	Available	Available	
	Focus	Focusing	Motorized	Motorized	Motorized
Stroke		101 mm (motorized)	101 mm (motorized)	75 mm (motorized)	
Objective lens		DSX20-UZH, DSX20-SZH DSX20-MZH	DSX10-SXLOB	DSX10-XLOB	UIS2
	Maximum sample height		50 mm	115 mm	145 mm
	Maximum sample height (free-angle observation)		50 mm	50 mm	50 mm
	Parfocal distance		140 mm	75 mm	45 mm
	Total magnification ³		20.9X-1461X	43.8X-5845X	26.1X-7307X
Actual FOV		18182 \times 13317 μ m 260 \times 190 μ m	8658 \times 6341 μ m 65 \times 48 μ m	14546 \times 10654 μ m 52 \times 38 μ m	
*1 Calibration by an Evident or a dealer service technician is necessary. To guarantee the accuracy of XY, calibration with a DSX-CALS-HR (calibration sample) is required.					
*2 When used with a 20X or higher objective.					
*3 On a 27-inch 4K monitor, scale setting: 175%, anti-vibration mode: off, fit to window mode.					
Stage		DSX20-TMTS	DSX20-RMTS	DSX20-LMTS	U-SIC4R
	XY stage: motorized/manual	Motorized	Motorized	Motorized	Manual
	XY stroke	100 \times 100 mm	Stroke priority mode: 100 mm \times 100 mm Rotation priority mode: 50 mm \times 50 mm	200 \times 100 mm	100 \times 105 mm
	Transmitted lighting	Integrated (PO, DF, BF, OBQ modes optional)	Not available	Not available	Not available
	Rotation angle	Not available	Available Stroke priority mode: $\pm 20^\circ$ Rotation priority mode: $\pm 90^\circ$	Not available	Not available
	Display rotation angle	Not available	GUI	Not available	Not available
Maximum load capacity	5 kg (11 lb)	5 kg (11 lb)	5 kg (11 lb)	1 kg (2.2 lb)	
Frame		DSX20-UF	DSX20-TF		
	Z-axis stroke	50 mm (manual)	50 mm (manual)		
	Tilt observation	Not available	Available: $\pm 90^\circ$		
	Tilt angle display	Not available	GUI		
Tilt angle method	Not available	Manual, fix/release handle			
Macro camera	Image sensor	1/2.5-inch color CMOS image sensor, rolling shutter			
	Image size	1:1 display, 1944 \times 1944 4:3 display, 1944 \times 1458 Full HD display, 1920 \times 1458			
Size of the field of view (horizontal)	81 mm to ∞				

DSX2000 Specifications and Dimensions

		DSX20-UF	DSX20-TF
Display	Screen size	27 inch / 32 inch	
	Resolution	Full HD: 1920 × 1080; 4K: 3840 × 2160	
System total		Upright frame system	Tilt frame system
	Weight (frame, head, motorized stage, display, and console)	54.7 kg (120 lb)	51.7 kg (113 lb)
	Power consumption	100–120V / 220–240 V, 1.1/0.54A, 50 Hz/60 Hz	100–120V / 220–240 V, 1.1/0.54A, 50 Hz/60 Hz
Software			
PRECiV DSX PRECiV ADM	Included: device control, video recording, time-lapse imaging, large panorama acquisition, extended focus imaging, 3D image acquisition, Z-stack acquisition, position list navigation, best image function, extended 2D measurements, 3D measurements, reporting tools, neural network processing, macro recorder, technical cleanliness analysis (available only on the MZH model with PRECiV ADM)		
Operating system	Windows 11–64 bit		
Network connectivity	Compatible with most popular antiviruses, Windows security updates allowed, images can be saved directly to OneDrive.		
Reporting application	Microsoft 365/Microsoft Office 365, Office 2024, Office 2021, Office 2019		
Optional software	Analysis Application Software, Count and Measure, Neural Network Training, Materials Solutions (Grain Size, Cast Iron, Phase Analysis, Porosity, Particle Size Distribution, Non-Metallic Inclusions, Layer Thickness, Coating Thickness).		
Customization	Included: customizable user interface for predefined workflow creation Optional: wafer navigation, automated analysis on specific samples		

Dimensions

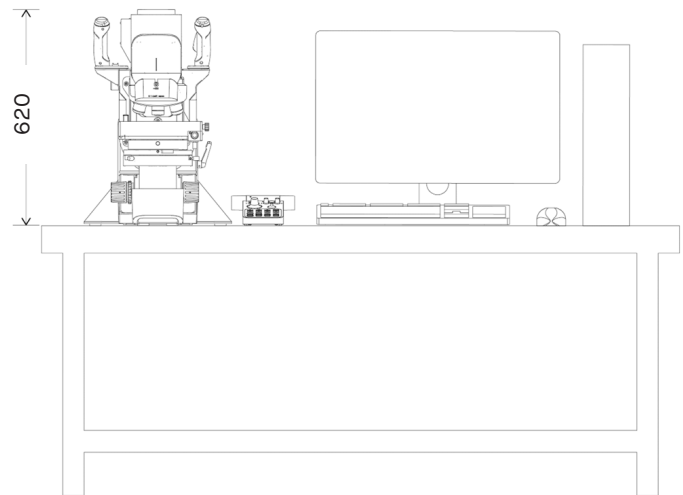
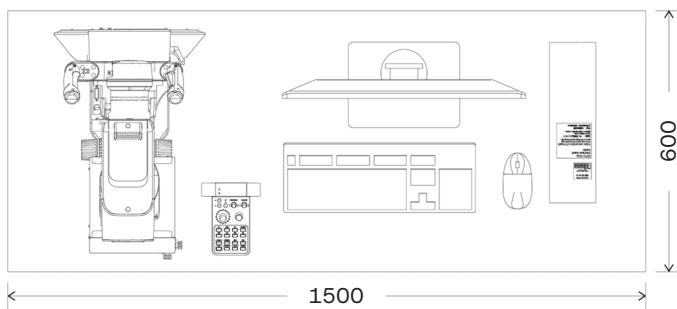

DSX20-MZH / DSX20-RMTS / DSX20-TF

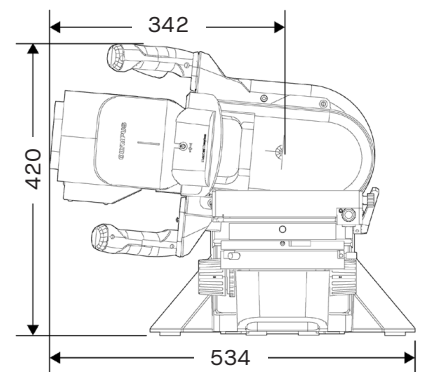
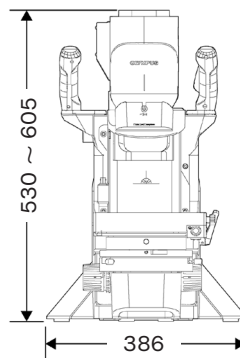
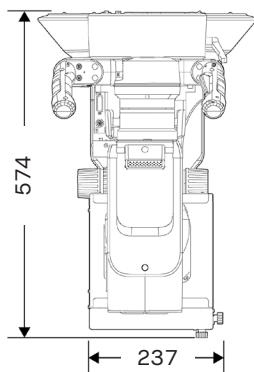

EVIDENT CORPORATION IS ISO14001 & ISO9001 CERTIFIED.
For details on certification registration, visit evidentscientific.com/en/legal/iso.

- PRECiV is a trademark of Evident Corporation or its subsidiaries.
- All company and product names are registered trademarks and/or trademarks of their respective owners.
- Specifications and appearances are subject to change without any notice or obligation on the part of the manufacturer.
- Illumination devices for microscope have suggested lifetimes. Periodic inspections are required. Please visit our website for details.
- This product is designed for use in industrial environments for the EMC performance. Using it in a residential environment may affect other equipment in the environment.